

# Basic randomness of nature and ether-drift experiments

M. Consoli, A. Pluchino and A. Rapisarda

Istituto Nazionale di Fisica Nucleare, Sezione di Catania  
Dipartimento di Fisica e Astronomia dell' Università di Catania  
Via Santa Sofia 64, 95123 Catania, Italy

## Abstract

We re-consider the idea that quantum fluctuations might reflect the existence of an ‘objective randomness’, i.e. a basic property of the vacuum state which is independent of any experimental accuracy of the observations or limited knowledge of initial conditions. Besides being responsible for the observed quantum behaviour, this might introduce a weak, residual form of ‘noise’ which is intrinsic to natural phenomena and could be important for the emergence of complexity at higher physical levels. By adopting Stochastic Electro Dynamics as a heuristic model, we are driven to a picture of the vacuum as a form of highly turbulent ether, which is deep-rooted into the basic foundational aspects of both quantum physics and relativity, and to search for experimental tests of this scenario. An analysis of the most precise ether-drift experiments, operating both at room temperature and in the cryogenic regime, shows that, at present, there is some ambiguity in the interpretation of the data. In fact the average amplitude of the signal has precisely the magnitude expected, in a ‘Lorentzian’ form of relativity, from an underlying stochastic ether and, as such, might not be a spurious instrumental effect. This puzzle, however, should be solved in a next future with the use of new cryogenically cooled optical resonators whose stability should improve by about two orders of magnitude. In these new experimental conditions, the persistence of the present amplitude would represent a clean evidence for the type of random vacuum we are envisaging.

# 1. Introduction

The authors of Ref.[1] have emphasized the possible existence of an ‘objective randomness’ as a basic property which is independent of any experimental accuracy of the observations or limited knowledge of initial conditions. In their opinion, this idea is so important that quantum mechanics should be generalized or, what is probably a more accurate perspective, should be recovered within a new physical principle where randomness is taken as a genuine property of nature. Actually, besides being responsible for the observed quantum behaviour, this basic property might introduce a residual form of *noise* that perturbs the system of interest in a weak but unpredictable way.

If this were true, there might be important consequences. In fact, it has becoming more and more evident that many classical and quantum systems can increase their efficiency thanks to the presence of noise. For example, it has been shown that noise-assisted enhancement effects are crucial for both classical and quantum communication channels. In this context, noise is supposed to play a fundamental role in generating the quantum coherence that seems to be involved in biological processes, such as pigment-protein complex for photosynthesis in sulphur bacteria [2]. But there are other examples in which efficiency of classical systems is reinforced by random noise, as for instance protein crystallization [3] or noise enhanced stability [4].

On this basis, one is tempted to assume that the inclusion of an objective noise, that reflects the effects of the environment and is intrinsic to natural phenomena, might induce a new framework where long-range correlations, complexity and also life, emerge as a natural consequence of underlying dynamical processes. In this context, it is worthwhile to quote a new and general approach in statistical mechanics, called *superstatistics* [5], which deals with spatio-temporally fluctuating intensive quantities in long-term stationary states of non-equilibrium systems. Within this approach, a changing, noisy environment, as when acting on a moving Brownian particle [6], leads to a statistical description where correlations and ”fat-tailed” Probability Density Functions, which characterize many complex systems, spontaneously emerge from a superposition of local Gaussian distributions. For small amplitudes of the fluctuations, such a behavior becomes universal and the first-order corrections to the ordinary Boltzmann factor correspond to those predicted by the so-called  $q$ -statistics. The latter is a generalization of standard statistical mechanics introduced by Tsallis in 1988 [7] in order to take into account systems, in particular those *at the edge of chaos*, where the presence of strong correlations, and the consequent lack of ergodicity, prevents the achieving of thermal equilibrium [8]. These last considerations reinforce the idea that a basic noise, at some elementary level, could be crucial for the emergence of complexity at higher physical levels.

Now, looking for an ultimate dynamical explanation, one could argue as follows. If the required form of noise cannot be predicted or controlled, it should be viewed as fundamentally simple. For the same reason also the appropriate model environment, in spite of its infinite number of degrees of freedom, may be considered as basically simple. Therefore, in this paper, we shall concentrate on the simplest possible state of any physical theory, the ‘vacuum’, and consider the following two aspects that were left open in Ref.[1]:

1) possible theoretical frameworks where the basic foundational aspects of both quantum physics and relativity point to a form of underlying random vacuum state

2) possible experimental checks of this scenario by looking for otherwise unexpected signatures of this vacuum state

Exploring these two aspects represents an essential step in order to take seriously the idea of the basic randomness of nature.

## 2. Stochastic Electro Dynamics and the idea of a turbulent ether

Let us start to discuss point 1). To this end, we shall tentatively adopt the framework of Stochastic Electro Dynamics (SED) [9, 10, 11, 12, 13]. By *tentatively* we mean that, in agreement with the point of view expressed by other authors [14], we do *not* claim that SED may fully replace or supplant the present quantum field theory. For instance, the problems posed by a suitable generalization that might include the existence of weak and strong interactions induce to give SED a limited heuristic significance <sup>1</sup>.

However, SED provides an alternative derivation of many physical results such as the blackbody radiation spectrum, the fluctuations in thermal radiation, the third law of thermodynamics, rotator and oscillator specific heats, the Van der Waals forces between macroscopic objects and between polarizable particles (see [12] and references quoted therein).

At the same time, the central premise of SED, which is relevant for our purpose, is that the quantum behaviour of particles can *also* be understood as the result of their classical interactions with a vacuum, random radiation field. This field, considered in a stationary state, is assumed to permeate all space and its action on the particles impresses upon them a stochastic motion with an intensity characterized by Planck’s constant. In this way, one can get insight into the basic foundational aspects of the quantum theory such as the wave-like properties of matter, indeterminacy, quantization,... For instance, in this picture, atomic

---

<sup>1</sup>Although limited, the heuristic value of SED in our context reflects the fact that weak and strong interactions were unknown at the beginning of 20th century when both relativity and quantum physics were introduced.

stability would originate from reaching that ‘quantum regime’ [15, 16] which corresponds to a dynamic equilibrium between the radiation emitted in the orbital motions and the energy absorbed in the highly irregular motions impressed by the vacuum stochastic field.

The general theoretical framework corresponds to the classical Lorentz-Dirac theory [17]. Thus, for instance, an electron in the field of a nucleus (in the non relativistic limit) is described by the equation of motion [18]

$$m \frac{d^2 \mathbf{r}}{dt^2} = -\frac{Ze^2 \mathbf{r}}{r^3} - e \left[ \mathbf{E} + \frac{1}{c} \frac{d\mathbf{r}}{dt} \times \mathbf{B} \right] + \mathbf{F}_{\text{reaction}} \quad (1)$$

where the back reaction of the ‘ether’ can be approximated as (see e.g. [19])

$$\mathbf{F}_{\text{reaction}} \sim \frac{2}{3} \frac{e^2}{c^2} \frac{d^3 \mathbf{r}}{dt^3} \quad (2)$$

and where  $\mathbf{E}$  and  $\mathbf{B}$  represent the electric and magnetic fields acting on the electron and include the ‘zero-point’ contributions

$$\mathbf{E}_{\text{ZP}}(\mathbf{r}, t) = \frac{1}{(L_x L_y L_z)^{1/2}} \sum_{n_x, n_y, n_z = -\infty}^{+\infty} \sum_{\lambda=1,2} \hat{\mathbf{e}}_{\mathbf{k}_n, \lambda} f_{\mathbf{k}_n, \lambda}(\mathbf{r}, t) \quad (3)$$

$$\mathbf{B}_{\text{ZP}}(\mathbf{r}, t) = \frac{1}{(L_x L_y L_z)^{1/2}} \sum_{n_x, n_y, n_z = -\infty}^{+\infty} \sum_{\lambda=1,2} (\mathbf{k}_n \times \hat{\mathbf{e}}_{\mathbf{k}_n, \lambda}) f_{\mathbf{k}_n, \lambda}(\mathbf{r}, t) \quad (4)$$

with

$$f_{\mathbf{k}_n, \lambda}(\mathbf{r}, t) = a_{\mathbf{k}_n, \lambda} \cos(\mathbf{k}_n \cdot \mathbf{r} - \omega_n t) + b_{\mathbf{k}_n, \lambda} \sin(\mathbf{k}_n \cdot \mathbf{r} - \omega_n t) \quad (5)$$

Here  $L_x, L_y, L_z$  denote the linear dimensions of the system,  $n_x, n_y, n_z$  are relative integers,  $\mathbf{k}_n \equiv 2\pi \left( \frac{n_x}{L_x}, \frac{n_y}{L_y}, \frac{n_z}{L_z} \right)$ ,  $\omega_n = c|\mathbf{k}_n|$  and the polarization vectors satisfy the conditions  $\mathbf{k}_n \cdot \hat{\mathbf{e}}_{\mathbf{k}_n, \lambda} = 0$  and  $\hat{\mathbf{e}}_{\mathbf{k}_n, \lambda} \cdot \hat{\mathbf{e}}_{\mathbf{k}_n, \lambda'} = 0$  for  $\lambda \neq \lambda'$ . Finally, the coefficients  $a_{\mathbf{k}_n, \lambda}$  and  $b_{\mathbf{k}_n, \lambda}$  in the plane wave expansion represent independent random variables of the type that could be simulated by a random number generator routine with zero mean and second moment distributions

$$\langle a_{\mathbf{k}_n, \lambda}^2 \rangle = \langle b_{\mathbf{k}_n, \lambda}^2 \rangle = 2\pi \hbar \omega_n \quad (6)$$

in order to guarantee a Lorentz-invariant energy spectrum  $\rho_{\text{ZP}}(\omega) = \frac{\hbar \omega^3}{(2\pi c^3)}$ . In this sense, SED could be considered Lorentz classical electron theory with new boundary conditions and it is remarkable that numerical simulations [18] lead to electron trajectories that nicely agree with the probability density of the Schrödinger wave equation for the ground state of the hydrogen atom.

Therefore, in this scheme, one could argue that, by changing the boundary conditions in Lorentz theory, and thus replacing the vanishing field used to characterize the lowest energy state with a random zero-point field, we should now change the physical picture of the ether.

Apparently, this should no longer be thought as a stagnant fluid (for an observer at rest) or as a fluid in laminar motion (for an observer in uniform motion). Rather one is driven to represent the ether as a fluid in a state of *turbulent* motion.

To this end one can find several arguments. First of all, Maxwell equations can be derived formally as hydrodynamic fluctuations of an incompressible turbulent fluid [20, 21, 22, 23]. As in the original model proposed by Kelvin [24], the energy which is locally stored into the vortical motion becomes a source of elasticity and the fluid resembles an elastic medium that can support the propagation of transverse waves. This is also suggested by the formal equivalence [25, 26] between various systems of screw dislocations in an elastic solid and corresponding vortex fields in a liquid. In this way, the phenomenon of turbulence can provide a conceptual transition from fluid dynamics to a different realm of physics, that of elasticity, where the wave speed, that by itself is simply a quantity that remains invariant under changes of the *average* velocity of the fluid, acquires also the meaning of a limiting speed. This is due to the behaviour of the elastic energy of moving dislocations (taken as models for the ordinary ponderable matter) that increases proportionally to  $(1 - v^2/c^2)^{-1/2}$ , see e.g. [27]–[32]. This type of correspondence leads to that intuitive visualization of the relativistic effects which is characteristic of a Lorentzian approach.

The idea of an underlying turbulent ether is also needed if one wants to get in touch with the quantum theory. In fact, Onsager’s original observation [33] that in a turbulent fluid with zero viscosity (i.e. infinite Reynolds number) the velocity field does not remain a differentiable function played a crucial role in Nelson’s stochastic derivation [34] of the Schrödinger equation. In his view, the induced particle ‘Brownian motion in the aether’ [35] provides the physical mechanism that generates the quantum fluctuations. As it is well known, in spite of some differences [36], this idea of a fluid with very irregular and effectively random fluctuations had also been advocated by Bohm and Vigier [37].

On the other hand, it is also true that the method of stochastic quantization can be introduced as a pure theoretical construct <sup>2</sup>. In this sense, Nelson’s conclusive words (“I simply do not know whether the things I have been talking about are physics or formalism” [39]) suggest that the existence of a basic randomness in nature cannot be simply demonstrated in this way <sup>3</sup>.

---

<sup>2</sup>A notable exception is represented by Calogero’s semi-quantitative approach [38]. This is based on the chaotic structure of many-body classical systems and the long-range nature of the gravitational interaction. As a consequence of these facts, in addition to the standard gravitational effects, every particle should experience locally a stochastic acceleration field (due to the rest of the Universe) which, remarkably, appears to have the right order of magnitude to explain the value of  $\hbar$ .

<sup>3</sup>For instance, in the Parisi-Wu stochastic quantization [40] the quantum theory corresponds to the equilibrium limit of a statistical system coupled to a thermal reservoir. This system evolves in a new fictitious time direction  $t$  until it reaches the equilibrium for  $t \rightarrow \infty$  [41].

Instead, to support the idea of an underlying turbulent ether, one could look for some unexpected experimental signature, thus coming to our point 2). But what kind of experiment could ever detect a zero-viscosity fluid? The implicit assumption made by all authors is that a ‘subquantal’ ether (if any) is so elusive that its existence can only be deduced *indirectly*, i.e. through the deviation of the microsystems from the classical behaviour. However, what about those highly sensitive ‘ether-drift’ experiments that, since the original Michelson-Morley experiment, have deeply influenced our vision of relativity? Do they show any evidence for a non zero effect?

At first sight, this possibility may seem in blatant contradiction with Lorentz transformations. However, this is not necessarily true. In fact, the speed of light in the vacuum, say  $c_\gamma$ , might not coincide *exactly* with the basic parameter  $c$  entering Lorentz transformations, see e.g. Ref.[42]. For instance, as stressed in [43], this could happen in an ‘emergent-gravity’ scenario where, as in our case, one tends to consider the physical vacuum as being not trivially ‘empty’. In this framework, the space-time curvature observed in a gravitational field could represent an effective phenomenon, analogously to a hydrodynamic description of moving fluids on length scales that are much larger than the size of the elementary constituents of the fluid [44, 45, 46]. Thus, although space-time is exactly flat at the very fundamental level, one might be faced with forms of curved ‘acoustic’ metrics in which  $c_\gamma \neq c$  thus opening the possibility of a tiny but non-zero ether drift.

Here we want to emphasize that, in a scenario where one is taking seriously a model of turbulent ether, there might be non trivial modifications in the interpretation of the data. In fact, in the traditional analysis of the ether-drift experiments, the hypothetical, preferred reference frame associated with the ether has always been assumed to occupy a definite, fixed location in space. This induces to search for smooth time modulations of the signal that might be synchronous with the Earth’s rotation and its orbital revolution. However, suppose that the ether were indeed similar to a turbulent fluid. On the one hand, this poses the theoretical problem of how to relate the macroscopic motions of the Earth’s laboratory (daily rotation, annual orbital revolution,...) to the microscopic measurement of the speed of light inside the optical cavities. On the other hand, from an experimental point of view, it suggests sizeable random fluctuations of the signal that could be erroneously interpreted as a mere instrumental effect. Since the ultimate implications of our continuous flowing in such a medium could be substantial, we believe that it is worth to re-discuss these experiments in some detail by providing the reader with the essential ingredients for their interpretation . After all, other notable examples are known (e.g. the Cosmic Microwave Background Radiation) where, at the beginning, an important physical signal was interpreted as a mere instrumental effect.

In the following, we shall first review in Sect.3 the motivations to re-propose a modern

form of Lorentzian relativity, in connection with the emergent-gravity scenario, and in Sect.4 the problem of measuring the speed of light in vacuum optical cavities placed on the Earth's surface. More technical aspects will be discussed in Sects.5 and 6. These aspects are essential to fully appreciate the puzzle posed by the present experimental situation: is the observed signal a spurious instrumental effect or a non-trivial physical manifestation of an underlying stochastic ether? Finally, Sect.7 will contain a summary and our conclusions with an outlook on the planned experimental improvements.

### 3. Lorentzian relativity and the emergent-gravity scenario

There is a basic controversy about relativity that dates back to its origin and concerns the interpretation of Lorentz transformations. Do they originate from the *relative* motion of any pair of observers  $S'$  and  $S''$ , as in Einstein's special relativity, or from the *individual* motion of each observer with respect to a hypothetical preferred reference frame  $\Sigma$  as in the Lorentz-Poincaré formulation? As pointed out by several authors, see e.g. [47, 48, 49, 50], there is no simple answer to this question. In fact, Lorentz transformations have a group structure. Thus if  $S'$  were individually related to  $\Sigma$  by a Lorentz transformation with dimensionless velocity parameter  $\beta' = v'/c$  and  $S''$  were related to  $\Sigma$  by a Lorentz transformation with parameter  $\beta'' = v''/c$ , the two frames  $S'$  and  $S''$  would also be mutually connected by a Lorentz transformation with relative velocity parameter

$$\beta_{\text{rel}} = \frac{\beta' - \beta''}{1 - \beta'\beta''} \equiv \frac{v_{\text{rel}}}{c} \quad (7)$$

(we restrict for simplicity to one-dimensional motions). This leads to a substantial quantitative equivalence of the two formulations for most standard experimental tests where one just compares the relative measurements of a pair of observers<sup>4</sup>.

But now, what about ether-drift experiments? In this context, the basic issue concerns the value of  $c_\gamma$ , the speed of light in the vacuum. Does it coincide *exactly* [42] with the basic parameter  $c$  entering Lorentz transformations? Up to now, the apparent failure of all attempts to measure the individual  $\beta'$ ,  $\beta''$ ,... has been interpreted as an experimental indication for  $c_\gamma = c$  and this has provided, probably, the main motivation for the wide preference given today to special relativity.

---

<sup>4</sup>A clean and authoritative statement of this substantial experimental equivalence could already be found in Ehrenfest's inaugural lecture [51] held in Leyden on December 4th, 1912 "So, we see that the ether-less theory of Einstein demands exactly the same here as the ether theory of Lorentz. It is, in fact, because of this circumstance, that according to the Einsteinian theory an observer must observe the exact same contractions, changes of rates, etc. in the measuring rods, clocks etc. moving with respect to him as according to the Lorentzian theory. And let it be said here right away in all generality. As a matter of principle, there is no experimentum crucis between these two theories".

However, if  $c_\gamma = c$ , also in the Lorentz-Poincaré formulation relativistic effects conspire to make undetectable a state of absolute motion in Michelson-Morley experiments. Therefore, it is only the conceptual relevance of retaining a physical substratum in the theory that may induce to re-discover the potentially profound implications of the ‘Lorentzian’ approach and explore scenarios with tiny effects producing  $c_\gamma \neq c$ . To this end, as anticipated, one could consider the emergent-gravity scenario [44, 45] where the space-time curvature observed in a gravitational field becomes an effective phenomenon, analogously to a hydrodynamic description of moving fluids.

In this perspective, local distortions of the underlying ethereal medium could produce local modifications of the basic space-time units which are known, see e.g. [52, 53], to represent an alternative way to generate an effective non-trivial curvature. This point of view has been vividly represented by K. Thorne in one of his books [54]: ”Is space-time really curved ? Isn’t conceivable that space-time is actually flat, but clocks and rulers with which we measure it, and which we regard as perfect, are actually rubbery ? Might not even the most perfect of clocks slow down or speed up and the most perfect of rulers shrink or expand, as we move them from point to point and change their orientations ? Would not such distortions of our clocks and rulers make a truly flat space-time appear to be curved ? Yes”.

By following this type of interpretation, one could first consider a simplest two-parameter scheme [46] in which there are simultaneous re-scalings of i) any mass  $m$  (and binding energy) and of ii) the velocity of light in the vacuum as with a non-trivial vacuum refractive index, i.e.

$$m \rightarrow \hat{m}(x) \qquad c_\gamma \rightarrow \frac{c}{\mathcal{N}(x)} \qquad (8)$$

In this case, the physical units would also be rescaled

$$\hat{t}(x) = \frac{\hbar}{\hat{m}(x)c^2} \equiv \lambda(x)t \qquad \hat{l}(x) = \frac{\hbar}{\hat{m}(x)c} \equiv \lambda(x)l \qquad (9)$$

producing the effective metric structure ( $A = c^2 \frac{\lambda^2}{\mathcal{N}^2}$  and  $B = \lambda^2$ )

$$g_{\mu\nu} = \text{diag}(A, -B, -B, -B) \qquad (10)$$

whose consistency with experiments requires the weak-field identification with the Newtonian potential

$$\mathcal{N} \sim 1 + 2 \frac{|U_N|}{c^2} \qquad \lambda \sim 1 + \frac{|U_N|}{c^2} \qquad (11)$$

Then, more complicated metrics with off-diagonal elements  $g_{0i} \neq 0$  and  $g_{ij} \neq 0$  can be obtained by applying boosts and rotations to Eq.(10) thus basically reproducing the picture of the curvature effects in a moving fluid. In this way, one is driven to consider the possibility of a non-zero (but admittedly extremely small) light anisotropy that could be measured in



the present generation of precise ether-drift experiments. This other part will be discussed in the following section.

## 4. The speed of light in the vacuum

After having discussed why gravity might induce local modifications of the basic space-time units, let us now consider the problem of measuring the speed of light. On a general ground, to determine speed as (distance moved)/(time taken), one must first choose some standards of distance and time. Since different choices can give different answers, we shall adopt in the following the point of view of special relativity where the speed of light in the vacuum  $c_\gamma$ , when measured in an inertial frame, coincides with the basic parameter  $c$  that enters Lorentz transformations. However, inertial frames are just an idealization. Therefore the appropriate realization is to assume *local* standards of distance and time such that the identification  $c_\gamma = c$  holds as an asymptotic relation in the physical conditions which are as close as possible to an inertial frame, i.e. *in a freely falling frame* (at least by restricting to a space-time region small enough that tidal effects of the external gravitational potential  $U_{\text{ext}}(x)$  can be ignored). This is essential to obtain an operative definition of the otherwise unknown parameter  $c$ . At the same time, the consistency of this scheme can be checked by comparing with experiments.

In fact, with these premises, light propagation for an observer  $S'$  sitting on the Earth's surface can be described with increasing degrees of approximations [43]:

i)  $S'$  is considered a freely falling frame. This amounts to assume  $c_\gamma = c$  so that, given two events which, in terms of the local space-time units of  $S'$ , differ by  $(dx, dy, dz, dt)$ , light propagation is described by the condition (ff='free-fall')

$$(ds^2)_{\text{ff}} = c^2 dt^2 - (dx^2 + dy^2 + dz^2) = 0 \quad (12)$$

ii) Now, is really the Earth a freely-falling frame? To a closer look, in fact, an observer  $S'$  placed on the Earth's surface can only be considered a freely-falling frame up to the presence of the Earth's gravitational field. Its inclusion leads to tiny deviations from the standard Eq.(12). These can be estimated by considering  $S'$  as a freely-falling frame (in the same external gravitational field described by  $U_{\text{ext}}(x)$ ) that however is also carrying on board a heavy object of mass  $M$  (the Earth's mass itself) that affects the effective local space-time structure (see Fig.1). To derive the required correction, let us again denote by  $(dx, dy, dz, dt)$  the local space-time units of the freely-falling observer  $S'$  in the limit  $M = 0$  and by  $\delta U$  the extra Newtonian potential produced by the heavy mass  $M$  at the experimental set up where one wants to describe light propagation. From Eqs.(10) and (11), in an emergent-gravity

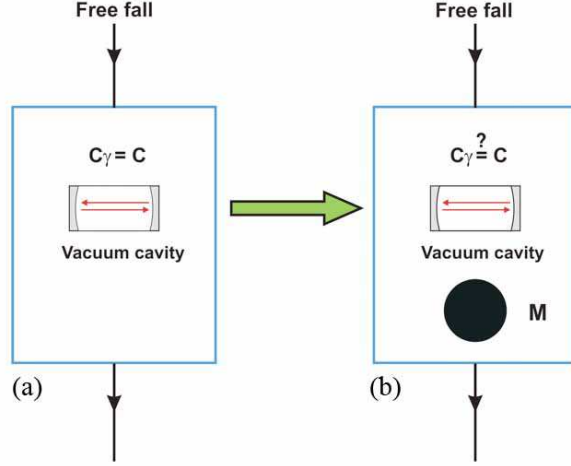

Figure 1: A pictorial representation of the effect of a heavy mass  $M$  carried on board of a freely-falling system, case (b). With respect to case (a), in a flat-space picture of gravity, the mass  $M$  modifies the effective, local space-time structure by re-scaling the physical units  $(dx, dy, dz, dt) \rightarrow (d\hat{x}, d\hat{y}, d\hat{z}, d\hat{t})$  and introducing a non-trivial refractive index  $\mathcal{N} \neq 1$  so that now  $c_\gamma \neq c$ .

scenario, light propagation for the  $S'$  observer can then be described by the condition [43]

$$(ds^2)_{\delta U} = \frac{c^2 d\hat{t}^2}{\mathcal{N}^2} - (d\hat{x}^2 + d\hat{y}^2 + d\hat{z}^2) = 0 \quad (13)$$

where, to first order in  $\delta U$ , the space-time units  $(d\hat{x}, d\hat{y}, d\hat{z}, d\hat{t})$  are related to the corresponding ones  $(dx, dy, dz, dt)$  for  $\delta U = 0$  through an overall re-scaling factor

$$\lambda = 1 + \frac{|\delta U|}{c^2} \quad (14)$$

and we have also introduced the vacuum refractive index

$$\mathcal{N} = 1 + 2\frac{|\delta U|}{c^2} \quad (15)$$

Therefore, to this order, light is formally described as in General Relativity where one finds the weak-field, isotropic form of the metric

$$(ds^2)_{\text{GR}} = c^2 dT^2 \left(1 - 2\frac{|U_N|}{c^2}\right) - (dX^2 + dY^2 + dZ^2) \left(1 + 2\frac{|U_N|}{c^2}\right) \equiv c^2 d\tau^2 - dl^2 \quad (16)$$

In Eq.(16)  $U_N$  denotes the Newtonian potential and  $(dT, dX, dY, dZ)$  arbitrary coordinates defined for  $U_N = 0$ . Finally,  $d\tau$  and  $dl$  denote the elements of proper time and proper length

in terms of which, in General Relativity, one would again deduce from  $ds^2 = 0$  the same universal value  $c = \frac{dl}{d\tau}$ . This is the basic difference with Eqs.(13)-(15) where the physical unit of length is  $\sqrt{d\hat{x}^2 + d\hat{y}^2 + d\hat{z}^2}$ , the physical unit of time is  $d\hat{t}$  and instead a non-trivial refractive index  $\mathcal{N}$  is introduced. For an observer placed on the Earth's surface, its value is

$$\mathcal{N} - 1 \sim \frac{2G_N M}{c^2 R} \sim 1.4 \cdot 10^{-9} \quad (17)$$

$M$  and  $R$  being respectively the Earth's mass and radius.

iii) Differently from General Relativity, in a flat-space interpretation with re-scaled units  $(d\hat{x}, d\hat{y}, d\hat{z}, d\hat{t})$  and  $\mathcal{N} \neq 1$ , the speed of light in the vacuum  $c_\gamma$  no longer coincides with the parameter  $c$  entering Lorentz transformations. Therefore, as a general consequence of Lorentz transformations, an isotropic propagation as in Eq.(13) can only be valid for a special state of motion of the Earth's laboratory. This provides the operative definition of a preferred reference frame  $\Sigma$  while for a non-zero relative velocity  $\mathbf{V}$  one expects off diagonal elements  $g_{0i} \neq 0$  in the effective metric and a tiny light anisotropy. As shown in Ref.[43], to first order in both  $(\mathcal{N} - 1)$  and  $V/c$  one finds

$$g_{0i} \sim 2(\mathcal{N} - 1) \frac{V_i}{c} \quad (18)$$

These off diagonal elements can be imagined as being due to a directional polarization of the vacuum induced by the now moving Earth's gravitational field and express the general property [55] that any metric, locally, can always be brought into diagonal form by suitable rotations and boosts. In this way, by introducing  $\beta = V/c$ ,  $\kappa = (\mathcal{N}^2 - 1)$  and the angle  $\theta$  between  $\mathbf{V}$  and the direction of light propagation, one finds, to  $\mathcal{O}(\kappa)$  and  $\mathcal{O}(\beta^2)$ , the one-way velocity [43]

$$c_\gamma(\theta) = \frac{c}{\mathcal{N}} \left[ 1 - \kappa\beta \cos\theta - \frac{\kappa}{2}\beta^2(1 + \cos^2\theta) \right] \quad (19)$$

and a two-way velocity of light

$$\begin{aligned} \bar{c}_\gamma(\theta) &= \frac{2c_\gamma(\theta)c_\gamma(\pi + \theta)}{c_\gamma(\theta) + c_\gamma(\pi + \theta)} \\ &\sim \frac{c}{\mathcal{N}} \left[ 1 - \beta^2 \left( \kappa - \frac{\kappa}{2} \sin^2\theta \right) \right] \end{aligned} \quad (20)$$

This allows to define the RMS [56, 57] anisotropy parameter  $\mathcal{B}$  through the relation

$$\frac{\Delta\bar{c}_\theta}{c} = \frac{\bar{c}_\gamma(\pi/2 + \theta) - \bar{c}_\gamma(\theta)}{\langle \bar{c}_\gamma \rangle} \sim \mathcal{B} \frac{V^2}{c^2} \cos(2\theta) \quad (21)$$

with

$$|\mathcal{B}| \sim \frac{\kappa}{2} \sim \mathcal{N} - 1 \quad (22)$$

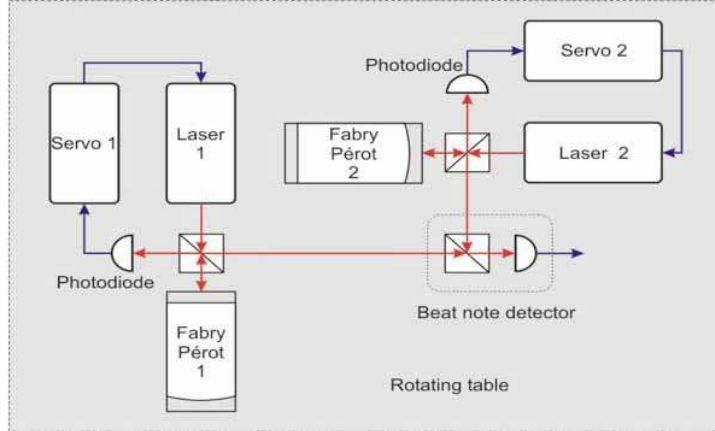

Figure 2: *The scheme of a modern ether-drift experiment. The frequencies  $\nu_1$  and  $\nu_2$  of the signals from the two Fabry-Pérot resonators are compared in the beat note detector that provides the frequency shift  $\Delta\nu = \nu_1 - \nu_2$ . In this picture, the apparatus is fully symmetric. On the other hand, in Ref.[59] only one of the two resonators was rotating while the other was kept fixed in the laboratory and oriented north-south.*

From the previous analysis, by replacing the value of the refractive index Eq.(17) and adopting, as a rough order of magnitude, the typical value of most cosmic motions  $V \sim 300$  km/s<sup>5</sup>, one expects a tiny fractional anisotropy

$$\frac{\langle \Delta \bar{c}_\theta \rangle}{c} \sim |\mathcal{B}| \frac{V^2}{c^2} = \mathcal{O}(10^{-15}) \quad (23)$$

that could finally be detected in the present, precise ether-drift experiments. These experiments will be discussed in the following section.

## 5. Ether-drift experiments and stochastic ether

In the present ether-drift experiments one measures the frequency shift, i.e. the beat signal,  $\Delta\nu$  of two cavity-stabilized lasers (see Fig.2) whose definite non-zero value would provide a direct measure of an anisotropy of the velocity of light [58]. In this framework, the possible time modulation of the signal that might be induced by the Earth's rotation (and its orbital revolution) has always represented a crucial ingredient for the analysis of the data. For instance, let us consider the relative frequency shift for the experiment of Ref.[59]. Here the basic

<sup>5</sup>For instance, from the motion of the Solar System within the Galaxy, or with respect to the centroid of the Local Group or with respect to the CMBR, one gets respectively  $V \sim 240, 320, 370$  km/s.

concept of light anisotropy Eq.(21) as a second-harmonic effect leads to the parametrization

$$\frac{\Delta\bar{c}_\theta(t)}{c} = \frac{\Delta\nu(t)}{\nu_0} = S(t) \sin 2\omega_{\text{rot}}t + C(t) \cos 2\omega_{\text{rot}}t \quad (24)$$

where  $\nu_0$  indicates the reference frequency of the two resonators and  $\omega_{\text{rot}}$  is the rotation frequency of one resonator with respect to the other which is kept fixed in the laboratory and oriented north-south. If one assumes the picture of a *fixed* preferred frame  $\Sigma$  then, for short-time observations of 1-2 days, the time dependence of a hypothetical physical signal can only be due to (the variations of the projection of the Earth's velocity  $\mathbf{V}$  in the interferometer's plane caused by) the Earth's rotation. In this case, the two functions  $S(t)$  and  $C(t)$  admit the simplest Fourier expansion [59] ( $\tau = \omega_{\text{sid}}t$  is the sidereal time of the observation in degrees)

$$S(t) = S_0 + S_{s1} \sin \tau + S_{c1} \cos \tau + S_{s2} \sin(2\tau) + S_{c2} \cos(2\tau) \quad (25)$$

$$C(t) = C_0 + C_{s1} \sin \tau + C_{c1} \cos \tau + C_{s2} \sin(2\tau) + C_{c2} \cos(2\tau) \quad (26)$$

with *time-independent*  $C_k$  and  $S_k$  Fourier coefficients. Thus, by accepting this theoretical framework, it becomes natural to average the various  $C_k$  and  $S_k$  obtained from fits performed during a 1-2 day observation period. By further averaging over many short-period experimental sessions, the data support the general conclusion [60, 61, 62] that, although the typical instantaneous  $S(t)$  and  $C(t)$  are  $\mathcal{O}(10^{-15})$ , the global averages  $(C_k)^{\text{avg}}$  and  $(S_k)^{\text{avg}}$  for the Fourier coefficients are much smaller, at the level  $\mathcal{O}(10^{-17})$ , and, with them, the derived parameters entering the phenomenological SME [63] and RMS [56, 57] models.

However, there might be different types of ether-drift where the straightforward parameterizations Eqs.(25), (26) and the associated averaging procedures are *not* allowed. Therefore we believe that, before assuming any definite theoretical scenario, one should first ask: if light were really propagating in a physical medium, an ether, and not in a trivial empty vacuum, how should the motion of (or in) this medium be described? Namely, could this relative motion exhibit variations that are *not* only due to known effects as the Earth's rotation and orbital revolution?

The point is that, by representing the physical vacuum as a fluid, the standard assumption of smooth sinusoidal variations of the signal, associated with the Earth's rotation (and its orbital revolution), corresponds to assume the conditions of a pure laminar flow associated with simple regular motions. Instead, by adopting the model of an underlying turbulent medium there might be other forms of time modulations. In this alternative scenario, the same basic experimental data might admit a different interpretation and a definite instantaneous signal  $\Delta\nu(t) \neq 0$  could become consistent with  $(C_k)^{\text{avg}} \sim (S_k)^{\text{avg}} \sim 0$ .

To exploit the possible implications, let us first recall the general aspects of any turbulent flow. This is characterized by extremely irregular variations of the velocity, with time at

each point and between different points at the same instant, due to the formation of eddies [64]. For this reason, the velocity continually fluctuates about some mean value and the amplitude of these variations is *not* small in comparison with the mean velocity itself. The time dependence of a typical turbulent velocity field can be expressed as [64]

$$\mathbf{v}(x, y, z, t) = \sum_{p_1 p_2 \dots p_n} \mathbf{a}_{p_1 p_2 \dots p_n}(x, y, z) \exp(-i \sum_{j=1}^n p_j \phi_j) \quad (27)$$

where the quantities  $\phi_j = \omega_j t + \beta_j$  vary with time according to fundamental frequencies  $\omega_j$  and depend on some initial phases  $\beta_j$ . As the Reynolds number  $\mathcal{R}$  increases, the total number  $n$  of  $\omega_j$  and  $\beta_j$  increases thus suggesting a sequence where laminar flow first becomes periodic, then quasi-periodic and finally highly turbulent. In this limit, where  $\mathcal{R} \rightarrow \infty$ , the required number of frequencies diverges so that the theory of such a turbulent flow must be a statistical theory.

Now, as anticipated in Sect.2, there are arguments to consider the limit of an ether with vanishingly small viscosity where, indeed, the relevant Reynolds numbers should become infinitely large in most regimes. In this case, one is faced precisely with the limit of a fully developed turbulence where the temporal analysis of the flow requires an extremely large number of frequencies and the physical vacuum behaves as a *stochastic* medium. Thus random fluctuations of the signal, superposed on the smooth sinusoidal behaviour associated with the Earth's rotation (and orbital revolution), would produce deviations of the time dependent functions  $S(t)$  and  $C(t)$  from the simple structure in Eqs.(25) and (26) and an effective temporal dependence of the fitted  $C_k = C_k(t)$  and  $S_k = S_k(t)$ . In this situation, due to the strong cancelations occurring in vectorial quantities when dealing with stochastic signals, one could easily get vanishing global inter-session averages

$$(C_k)^{\text{avg}} \sim (S_k)^{\text{avg}} \sim 0 \quad (28)$$

Nevertheless, as it happens with the phenomena affected by random fluctuations, the average quadratic amplitude of the signal could still be preserved. To this end, let us re-write Eq.(24) as

$$\frac{\Delta \bar{c}_\theta(t)}{c} = \frac{\Delta \nu(t)}{\nu_0} = A(t) \cos(2\omega_{\text{rot}} t - 2\theta_0(t)) \quad (29)$$

where

$$C(t) = A(t) \cos 2\theta_0(t) \quad S(t) = A(t) \sin 2\theta_0(t) \quad (30)$$

so that

$$A(t) = \sqrt{S^2(t) + C^2(t)} \quad (31)$$

Here  $\theta_0(t)$  represents the instantaneous direction of a hypothetical ether-drift effect in the x-y plane of the interferometer (counted by convention from North through East so that North

is  $\theta_0 = 0$  and East is  $\theta_0 = \pi/2$ ). By also introducing the magnitude  $v = v(t)$  of the *projection* of the full  $\mathbf{V}$ , such that

$$v_x(t) = v(t) \sin \theta_0(t) \qquad v_y(t) = v(t) \cos \theta_0(t) \qquad (32)$$

and adopting the same notations as in Eq.(23), we obtain the theoretical relations [43]

$$A_{\text{th}}(t) = \frac{1}{2} |\mathcal{B}| \frac{v^2(t)}{c^2} \qquad (33)$$

and

$$C_{\text{th}}(t) = \frac{1}{2} |\mathcal{B}| \frac{v_y^2(t) - v_x^2(t)}{c^2} \qquad S_{\text{th}}(t) = \frac{1}{2} |\mathcal{B}| \frac{2v_x(t)v_y(t)}{c^2} \qquad (34)$$

In this way, in a stochastic ether, the positive-definite amplitude  $A(t)$  of the signal will have a definite non-zero average value  $\langle A \rangle$  and this can well coexist with  $\langle C_k \rangle^{\text{avg}} \sim \langle S_k \rangle^{\text{avg}} \sim 0$ . Physical conclusions will then require to first compare the measured value of  $\langle A \rangle$  with the short-term, stability limits of the individual optical resonators and then with the theoretical expectation (33).

## 6. Instrumental effects or fundamental noise?

To provide evidence that indeed, in ether-drift experiments, we might be faced with a form of fundamental noise from an underlying stochastic ether, the present, most precise experiments [61, 65] were considered in Ref.[43]. In the experimental apparatus of Ref.[65], to minimize all sources of systematic asymmetry, the two optical cavities were obtained from the same monolithic block of ULE (Ultra Low Expansion material). In these conditions, due to sophisticated electronics and temperature controls, the short-term (about 40 seconds) stability limits for the individual optical cavities are extremely high. Namely, for the non-rotating set up, by taking into account various systematic effects, one deduces stabilities  $(\delta\nu)_1 \sim (\delta\nu)_2 \sim \pm 0.05$  Hz for the individual cavities 1 and 2 and thus about  $\pm 2 \cdot 10^{-16}$  in units of a laser frequency  $\nu_0 = 2.82 \cdot 10^{14}$  Hz. This is of the same order of the *average* frequency shift between the two resonators, say  $(\Delta\nu)^{\text{avg}} \sim \pm 0.06$  Hz, when averaging the signal over a very large number of temporal sequences (see their Fig.9b).

However, the magnitude of the *instantaneous* frequency shift  $\Delta\nu(t)$  is much larger, say  $\pm 1$  Hz (see their Fig.9a), and so far has been interpreted as a spurious instrumental effect. To check this interpretation, we observe that, in the absence of any genuine physical signal, the frequency shift between the two resonators should exhibit the same typical instabilities  $(\delta\nu)_1$  and  $(\delta\nu)_2$  of the individual resonators and thus, for short-time observations, should be at the same level  $\pm 2 \cdot 10^{-16}$ . Instead, for the same non-rotating set up, the minimum noise in the frequency shift  $\Delta\nu$  was found about 10 times bigger, namely  $1.9 \cdot 10^{-15}$  (see Fig.8 of Ref.[65]).

Also the trend of this form of noise in the beat signal, as function of the averaging time, is different from the corresponding one observed in the individual resonators thus suggesting that the two types of noise might have different origin.

The authors tend to interpret this relatively large beat signal as cavity thermal noise and refer to [66]. However, this interpretation is not so obvious since the typical disturbances  $(\delta\nu)_1$  and  $(\delta\nu)_2$  in the *individual* cavities were reduced to a considerably lower level.

For a quantitative estimate of the amplitude  $A(t)$  of the signal we can consider the more recent paper [62] of the same authors. The physical second-harmonic part of the ether-drift effect, from their Eq.(1), can be expressed as <sup>6</sup>

$$\left(\frac{\Delta\nu(t)}{\nu_0}\right)^{\text{physical}} = 2B(t) \sin 2\omega_{\text{rot}}t + 2C(t) \cos 2\omega_{\text{rot}}t \equiv A^{\text{symm}}(t) \cos(2\omega_{\text{rot}}t - 2\theta_0(t)) \quad (35)$$

where

$$A^{\text{symm}}(t) = 2\sqrt{B^2(t) + C^2(t)} \quad (36)$$

Now the data of Ref.[62] confirm the above mentioned trend with average values  $\langle B \rangle$  and  $\langle C \rangle$  which are much smaller than their typical instantaneous values since one finds (see their Fig.3)

$$\langle B \rangle \sim \langle C \rangle \sim \mathcal{O}(10^{-17}) \quad (37)$$

Therefore the quadratic average values  $\langle B^2 \rangle$  and  $\langle C^2 \rangle$  are essentially determined by the variances  $\sigma_B \sim 7.5 \cdot 10^{-16}$  and  $\sigma_C \sim 6.1 \cdot 10^{-16}$  [62]. In this way, we obtain the experimental value

$$\langle A_{\text{exp}}^{\text{symm}} \rangle \sim 2\sqrt{\sigma_B^2 + \sigma_C^2} \sim 1.9 \cdot 10^{-15} \quad (38)$$

in good agreement with our theoretical expectation from Eqs.(17), (22) and (33) for the average Earth's velocity of most cosmic motions  $\sqrt{\langle v^2 \rangle} \sim 300$  km/s

$$\langle A_{\text{th}}^{\text{symm}} \rangle = 2\langle A_{\text{th}} \rangle = |\mathcal{B}| \frac{\langle v^2 \rangle}{c^2} \sim 1.4 \cdot 10^{-15} \frac{\langle v^2 \rangle}{(300 \text{ km/s})^2} \quad (39)$$

Similar conclusions can be obtained from the other experiment of Ref.[61] where the stability of the individual resonators is at the same level of a few  $10^{-16}$ . Nevertheless, the measured  $C(t)$  and  $S(t) \equiv B(t)$  entering the beat signal are found in the range  $\pm 1.2 \cdot 10^{-15}$  (see their Fig.4a) and are again interpreted in terms of a thermal noise of the individual cavities. Thus, in the present two most precise ether-drift experiments, the average amplitude of the signal is about 4-5 times larger than the short-term stability of the individual resonators and its measured value  $\langle A \rangle = \mathcal{O}(10^{-15})$  is completely consistent with our theoretical expectations.

---

<sup>6</sup>To make the comparison easier, we maintain the notations of Ref.[62] where  $B(t)$  is used to denote the same amplitude  $S(t)$  introduced before in Eq.(24) and the overall factor of 2 takes into account the differences with respect to Eq.(24) introduced by a fully symmetric apparatus.



Finally, as an additional check, a comparison with a previous experiment [67] operating in the cryogenic regime was also performed in Ref.[43]. Again, by restricting to the variable part of the signal which is less affected by spurious systematic effects (see Ref.[43]), the average amplitude was found  $\mathcal{O}(10^{-15})$ . Thus this stable value of about  $10^{-15}$  found in all experiments is unlike to represent a spurious instrumental artifact of the individual optical cavities of the type discussed in Ref.[66]. In fact, the estimate of Ref.[66] is based on the fluctuation-dissipation theorem, and therefore there is no reason that both room temperature and cryogenic experiments exhibit the same instrumental noise. This argument confirms that, at present, there is a basic ambiguity in the interpretation of the experimental data. The standard interpretation in terms of spurious instrumental effects of the individual optical cavities is by no means unique and the observed signal could also represent a fundamental noise associated with the underlying stochastic ether.

The puzzle, however, should be definitely solved in a next future. In fact, the authors of Ref.[61] are starting to upgrade their apparatus with cryogenically cooled sapphire optical cavities [68]. This should improve the short-term stability of the individual resonators by about two orders of magnitude (say well below the  $10^{-17}$  level). In these new experimental conditions, the persistence of an average amplitude  $\langle A \rangle = \mathcal{O}(10^{-15})$  (i.e. about 100 times larger) would represent an unambiguous evidence for the type of random vacuum we have been considering.

## 7. Summary and conclusions

In this paper, by following the authors of Ref.[1], we have re-considered the idea of an ‘objective randomness’ in nature as a basic concept, independent of any experimental accuracy of the observations or limited knowledge of initial conditions. This property of the vacuum, besides being responsible for the observed quantum behaviour, might introduce a weak, residual form of noise which is intrinsic to natural phenomena and could be important for the emergence of complexity at higher physical levels, as suggested by both theoretical and phenomenological evidence.

By looking for a definite dynamical framework, and adopting Stochastic Electro Dynamics as a heuristic model, we have been driven to the idea of the vacuum as an underlying zero-viscosity and highly turbulent ether, which is deep-rooted into the basic foundational aspects of both quantum physics and relativity, and to search for experimental tests of this scenario. Our analysis of the most precise ether-drift experiments (operating both at room temperature and in the cryogenic regime) shows that, at present, there is some ambiguity in the interpretation of the data. In fact, the average amplitude of the signal has precisely the magnitude expected, in a ‘Lorentzian’ form of relativity, from an underlying stochastic ether.

As such, it might not be a spurious instrumental effect of the individual optical resonators but the manifestation of that fundamental form of noise we have envisaged.

This puzzle, however, should be definitely solved in a next future with the use of new cryogenically cooled optical cavities whose individual stability should improve by about two orders of magnitude. In these conditions, the persistence of the present instantaneous beat signal between the two resonators would represent an unambiguous evidence for the type of random vacuum we have been considering. Namely, this would turn out to be similar to a polarizable medium, responsible for the apparent curvature effects seen in a gravitational field and, at the same time, a stochastic medium, similar to a zero-viscosity fluid in a turbulent state of motion, responsible for the observed strong random fluctuations of the signal. All together, the situation might resemble the discovery of the Cosmic Microwave Background Radiation that, at the beginning, was also interpreted as a mere instrumental effect. Such an experimental evidence for the stochastic nature of the underlying vacuum state would represent an important step forward in order to take seriously the idea (and start to explore the implications) of the basic randomness of nature.

### Acknowledgments

We thank L.Pappalardo for useful discussions and collaboration.

### References

- [1] P. Allegrini, M. Giuntoli, P. Grigolini and B. J. West, *Chaos, Solitons and Fractals*, **20** (2004) 11.
- [2] F. Caruso, S.F. Huelga, M.B. Plenio, *Phys. Rev. Lett.* **105** (2010) 190501; H. Lee et al., *Science* **316** (2007) 1462.
- [3] D. Frenkel, *Nature* **443** (2006) 641.
- [4] R. Mantegna and B. Spagnolo, *Phys. Rev. Lett.* **76** (1996) 563.
- [5] C.Beck and E.G.D.Cohen, *Physica A* **322** (2003) 267.
- [6] C.Beck and E.G.D.Cohen, *Phys. Rev. E* **72** (2005) 056133.
- [7] C. Tsallis, *J. Stat. Phys.* **52** (1988) 479
- [8] C.Tsallis, *Introduction to Nonextensive Statistical Mechanics. Approaching a Complex World*, Springer (2009).
- [9] T. H. Boyer, *Phys. Rev.* **182** (1969) 1374; *ibidem* **186** (1969) 1304.

- [10] T. W. Marshall, Proc. R. Soc. **A 276** (1963) 475.
- [11] T. W. Marshall, Proc. Cambridge Philos. Soc. **61** (1965) 537.
- [12] T. H. Boyer, Phys. Rev. **D11** (1975) 809.
- [13] L. de la Peña and A. M. Cetto, The Quantum Dice - An Introduction to Stochastic Electrodynamics, Kluwer Academic Publ., Dordrecht 1996.
- [14] B. Haisch, A. Rueda and Y. Dobyns, Annalen der Physik **10** (2001) 393.
- [15] H. E. Puthoff, Phys. Rev. **D35** (1987) 3266.
- [16] L. de la Peña and A. M. Cetto, Contribution from stochastic electrodynamics to the understanding of quantum mechanics, arXiv:quant-ph/050101.
- [17] P. A. M. Dirac, Proc. R. Soc. **A167** (1938) 148.
- [18] D. C. Cole and Y. Zou, Phys. Lett. **A317** (2003) 14.
- [19] W. Panofsky and M. Phillips, Classical electricity and Magnetism, Addison-Wesley Co. Inc., Reading Massachusetts, 1955, Chapt. 20.
- [20] O. V. Troshkin, Physica **A168** (1990) 881.
- [21] H. Marmanis, Physics of Fluids **10** (1998) 1428.
- [22] H. E. Puthoff, Linearized turbulent flow as an analog model for linearized General Relativity, arXiv:0808.3401 [physics.gen-ph].
- [23] T. Tsankov, Classical Electrodynamics and the Turbulent Aether Hypothesis, Preprint February 2009.
- [24] E. T. Whittaker, A history of the Theories of Aether and Electricity, Dover Publications, Inc. New York 1989.
- [25] M. J. Marcinkowski, Physica Status Solidi **152B** (1989) 9.
- [26] A. M. Kosevic, The Crystal Lattice: Phonons, Solitons, Superlattices, Wiley-VCH Verlag GmbH and Co. KGaA, Weinheim 2005, pp. 237-238.
- [27] C. F. Frank, Proc. Phys. Soc. **A 62** (1949) 131.
- [28] G. I. Taylor, Proc. R. Soc. **A 145** (1934) 362.
- [29] J. D. Eshelby, Proc. Phys. Soc. **A 62** (1949) 307.

- [30] H. Günther, *Physica Status Solidi* **149** (1988) 104.
- [31] A. Unzicker, What can Physics learn from Continuum Mechanics?, arXiv:gr-qc/0011064.
- [32] C. I. Christov, *Math. Comput. Simul.* **74** (2007) 93.
- [33] L. Onsager, *Nuovo Cimento, Suppl.* **6** (1949) 279.
- [34] E. Nelson, *Phys. Rev.* **150** (1966) 1079.
- [35] E. Nelson, *Dynamical Theories of Brownian Motion*, Princeton University Press 1967, Chapt. 15.
- [36] D. Bohm and B. J. Hiley, *Phys. Rep.* **172** (1989) 93.
- [37] D. Bohm and J. P. Vigier, *Phys. Rev.* **96** (1954) 208.
- [38] F. Calogero, *Phys. Lett.* **A228** (1997) 335.
- [39] E. Nelson, *Quantum Fluctuations*, Princeton University Press 1985, see Chapt. 4, ‘Physics or formalism?’.
- [40] G. Parisi and Y.S. Wu, *Sci. Sinica* **24** (1981) 483.
- [41] P. H. Damgaard and H. Hüffel, *Phys. Rep.* **152** (1987) 227.
- [42] G.F.R. Ellis and J. P. Uzan, *Am. J. Phys.* **73** (2005) 240.
- [43] M. Consoli and L. Pappalardo, *Gen. Rel. and Grav.* **42** (2010) 2585.
- [44] C. Barcelo, S. Liberati and M. Visser, *Class. Quantum Grav.* **18** (2001) 3595.
- [45] M. Visser, C. Barcelo and S. Liberati, *Gen. Rel. Grav.* **34** (2002) 1719.
- [46] M. Consoli, *Class. Quantum Grav.* **26** (2009) 225008.
- [47] J. S. Bell, How to teach special relativity, in *Speakable and unspeakable in quantum mechanics*, Cambridge University Press 1987, pag. 67.
- [48] H. R. Brown and O. Pooley, The origin of the space-time metric: Bell’s Lorentzian pedagogy and its significance in general relativity, in ‘Physics meets Philosophy at the Planck Scale’, C. Callender and N. Hugget Eds., Cambridge University Press 2000 (arXiv:gr-qc/9908048).
- [49] H. R. Brown, *Physical Relativity. Space-time structure from a dynamical perspective*, Clarendon Press, Oxford 2005.

- [50] M. Consoli and E. Costanzo, Phys. Lett. **A333** (2004) 355.
- [51] P. Ehrenfest, On the crisis of the light-ether hypothesis, Collected Scientific Papers, M. J. Klein Editor, North-Holland 1959, pp. 306-327.
- [52] R. P. Feynman, R. B. Leighton and M. Sands, The Feynman Lectures on Physics, Addison Wesley Publ. Co. 1963, Vol.II, Chapt. 42.
- [53] R. H. Dicke, Phys. Rev. **125** (1962) 2163.
- [54] K. Thorne, Black Holes and Time Warps: Einstein's Outrageous Legacy, W. W. Norton and Co. Inc, New York and London, 1994, see Chapt. 11 'What is Reality?'
- [55] A. M. Volkov, A. A. Izmet'sev and G. V. Skrotskij, Sov. Phys. JETP **32** (1971) 686.
- [56] H. P. Robertson, Rev. Mod. Phys. **21** (1949) 378.
- [57] R. M. Mansouri and R. U. Sexl, Gen. Rel. Grav. **8**(1977) 497.
- [58] For a comprehensive review of the present ether-drift experiments, see H. Müller et al., Appl. Phys. **B77** (2003) 719.
- [59] S. Herrmann, A. Senger, E. Kovalchuk, H. Müller and A. Peters, Phys. Rev. Lett. **95** (2005) 150401.
- [60] H. Müller et al., Phys. Rev. Lett. **99**, 050401 (2007).
- [61] S. Herrmann, et al., Phys.Rev. **D80** (2009) 105011.
- [62] Ch. Eisele, A. Newski and S. Schiller, Phys. Rev. Lett. **103** (2009) 090401.
- [63] A. Kostelecky and N. Russell, arXiv:0801.0287[hep-ph].
- [64] L. D. Landau and E. M. Lifshitz, Fluid Mechanics, Pergamon Press 1959, Chapt. III.
- [65] Ch. Eisele et al., Opt. Comm. **281** (2008) 1189.
- [66] K. Numata, A. Kemery and J. Camp, Phys. Rev. Lett. **93** (2004) 250602.
- [67] P. Antonini, M. Okhapkin, E. Göklü and S. Schiller, Phys. Rev. **A71** (2005) 050101(R).
- [68] M. Nagel et al., Testing Lorentz Invariance by Comparing Light Propagation in Vacuum and Matter, Presented at the Fifth Meeting on CPT and Lorentz Symmetry, Bloomington, Indiana, June 28-July 2, 2010, arXiv:1008.1205 [physics.ins-det].

# Basic randomness of nature and ether-drift experiments

M. Consoli, A. Pluchino and A. Rapisarda

Istituto Nazionale di Fisica Nucleare, Sezione di Catania  
Dipartimento di Fisica e Astronomia dell' Università di Catania  
Via Santa Sofia 64, 95123 Catania, Italy

## Abstract

We re-consider the idea that quantum fluctuations might reflect the existence of an ‘objective randomness’, i.e. a basic property of the vacuum state which is independent of any experimental accuracy of the observations or limited knowledge of initial conditions. Besides being responsible for the observed quantum behaviour, this might introduce a weak, residual form of ‘noise’ which is intrinsic to natural phenomena and could be important for the emergence of complexity at higher physical levels. By adopting Stochastic Electro Dynamics as a heuristic model, we are driven to a picture of the vacuum as a form of highly turbulent ether, which is deep-rooted into the basic foundational aspects of both quantum physics and relativity, and to search for experimental tests of this scenario. An analysis of the most precise ether-drift experiments, operating both at room temperature and in the cryogenic regime, shows that, at present, there is some ambiguity in the interpretation of the data. In fact the average amplitude of the signal has precisely the magnitude expected, in a ‘Lorentzian’ form of relativity, from an underlying stochastic ether and, as such, might not be a spurious instrumental effect. This puzzle, however, should be solved in a next future with the use of new cryogenically cooled optical resonators whose stability should improve by about two orders of magnitude. In these new experimental conditions, the persistence of the present amplitude would represent a clean evidence for the type of random vacuum we are envisaging.

# 1. Introduction

The authors of Ref.[1] have emphasized the possible existence of an ‘objective randomness’ as a basic property which is independent of any experimental accuracy of the observations or limited knowledge of initial conditions. In their opinion, this idea is so important that quantum mechanics should be generalized or, what is probably a more accurate perspective, should be recovered within a new physical principle where randomness is taken as a genuine property of nature. Actually, besides being responsible for the observed quantum behaviour, this basic property might introduce a residual form of *noise* that perturbs the system of interest in a weak but unpredictable way.

If this were true, there might be important consequences. In fact, it has becoming more and more evident that many classical and quantum systems can increase their efficiency thanks to the presence of noise. For example, it has been shown that noise-assisted enhancement effects are crucial for both classical and quantum communication channels. In this context, noise is supposed to play a fundamental role in generating the quantum coherence that seems to be involved in biological processes, such as pigment-protein complex for photosynthesis in sulphur bacteria [2]. But there are other examples in which efficiency of classical systems is reinforced by random noise, as for instance protein crystallization [3], noise enhanced stability [4] or stochastic resonance [5, 6].

On this basis, one is tempted to assume that the inclusion of an objective noise, that reflects the effects of the environment and is intrinsic to natural phenomena, might induce a new framework where long-range correlations, complexity and also life, emerge as a natural consequence of underlying dynamical processes. In this context, it is worthwhile to quote a new and general approach in statistical mechanics, called *superstatistics* [7], which deals with spatio-temporally fluctuating intensive quantities in long-term stationary states of non-equilibrium systems. Within this approach, a changing, noisy environment, as when acting on a moving Brownian particle [8], creates dynamical correlations which lead to a statistical description where ”fat-tailed” Probability Density Functions, that characterize many complex systems, spontaneously emerge from a superposition of local Gaussian distributions. For small amplitudes of the fluctuations, such a behavior becomes universal and the first-order corrections to the ordinary Boltzmann factor correspond to those predicted by the so-called *q*-statistics introduced by Tsallis in 1988 [9, 10]. These last considerations reinforce the idea that a basic noise, at some elementary level, could be crucial for the emergence of complexity at higher physical levels.

Now, looking for an ultimate dynamical explanation, one could argue as follows. If the required form of noise cannot be predicted or controlled, it should be viewed as fundamentally simple. For the same reason also the appropriate model environment, in spite of its infinite

number of degrees of freedom, may be considered as basically simple. Therefore, in this paper, we shall concentrate on the simplest possible state of any physical theory, the ‘vacuum’, and consider the following two questions that were left open in Ref.[1]:

1) do the basic foundational aspects of quantum physics and relativity point to some kind of random vacuum state?

2) are there experimental signatures of this vacuum state that might represent a fundamental form of noise?

Exploring these two aspects represents a preliminary step in order to take seriously the general framework illustrated above.

## **2. Stochastic Electro Dynamics and the idea of a turbulent ether**

Let us start to discuss question 1). Concerning the idea of an objective randomness, an important motivation, that originates within the quantum theory itself, was mentioned in Ref.[1]. Namely, one could try to modify the standard deterministic evolution of the quantum states with regard to the quantum theory of measurement and, in particular, to explain why macroscopic objects are not observed in a superposition of states. To this end, a number of models (for a complete review see Ref.[11]) was proposed to dynamically reduce the coherence between macroscopically distinct states. In this context, randomness plays a fundamental role in the original idea of Ghirardi, Rimini and Weber [12] of ‘spontaneous’ localizations of the microscopic systems. These processes should be considered a consequence of the stochastic nature of space-time and are extremely rare. However, they become important for a very large number of elementary constituents because, then, macroscopic objects cannot exist in a superposition of states for more than an infinitesimal fraction of time. From an experimental point of view, the permanent excitation of a body produced by the spontaneous localization processes of its constituents represents, in a sense, a fundamental form of noise that however is estimated to be too small to be detected with present technology.

Alternatively, one could start from classical physics and assume that the probabilistic aspects of quantum physics reflect the active role of the vacuum whose stochastic nature modifies the classical behaviour of the microsystems and provides the fundamental background for the observed quantum fluctuations. This general idea, shared by a large number of authors over the years (see e.g. the long list reported in Ref.[13]), has produced various formulations that sometimes differ non-trivially from each other and could be denoted as ‘stochastic’ or ‘hidden-variable’ models of quantum mechanics. In spite of the fact that, in some cases, the predictions of these models can be made to agree with those of the quantum theory, none of them can be considered a true ‘derivation’ of quantum mechanics from clas-



sical physics. However, this does not mean that these models are useless. In fact, they might allow asking questions that otherwise are not permissible in the standard quantum theory (e.g. the origin of atomic stability, quantization, indeterminacy,...).

Now, among such possible models, an interesting scenario is that of Stochastic Electro Dynamics (SED) [14, 15, 16, 17, 18]. It provides a definite classical framework that has genuine elements of randomness and, by its very nature, points to the basic foundational aspects of *both* quantum theory and relativity. As such, it will be tentatively adopted in the following. By *tentatively* we mean that SED is certainly not the only possible choice to discuss the general idea of a random vacuum. Also, in agreement with the point of view expressed by other authors [19], we do *not* claim SED to be a complete, consistent theory. For instance, the problems posed by a suitable generalization that might include the existence of weak and strong interactions induce to give SED a limited heuristic significance <sup>1</sup>.

However, SED provides an alternative derivation of many physical results such as the blackbody radiation spectrum, the fluctuations in thermal radiation, the third law of thermodynamics, rotator and oscillator specific heats, the Van der Waals forces between macroscopic objects and between polarizable particles (see [17] and references quoted therein).

At the same time, the central premise of SED, which is relevant for our purpose, is that the quantum behaviour of particles can *also* be understood as the result of their classical interactions with a vacuum, random radiation field. This field, considered in a stationary state, is assumed to permeate all space and its action on the particles impresses upon them a stochastic motion with an intensity characterized by Planck's constant. In this way, one can get insight into basic aspects of the quantum theory such as the wave-like properties of matter, indeterminacy, quantization,... For instance, in this picture, atomic stability would originate from reaching that 'quantum regime' [22, 23] which corresponds to a dynamic equilibrium between the radiation emitted in the orbital motions and the energy absorbed in the highly irregular motions impressed by the vacuum stochastic field.

The theoretical framework of SED corresponds to the classical Lorentz-Dirac theory [24]. Thus, for instance, an electron in the field of a nucleus (in the non relativistic limit) is described by the equation of motion [25]

$$m \frac{d^2 \mathbf{r}}{dt^2} = -\frac{Ze^2 \mathbf{r}}{r^3} - e \left[ \mathbf{E} + \frac{1}{c} \frac{d\mathbf{r}}{dt} \times \mathbf{B} \right] + \mathbf{F}_{\text{reaction}} \quad (1)$$

---

<sup>1</sup>Although limited, the heuristic value of SED in our context reflects the fact that weak and strong interactions were unknown at the beginning of 20th century when both relativity and quantum physics were introduced. In addition, the fact that the fine structure constant  $\alpha = \frac{e^2}{\hbar c} \sim 1/137$  is a pure number means that Planck's constant could also be expressed in terms of pure electromagnetic constants [20, 21].

where the back reaction of the ‘ether’<sup>2</sup> can be approximated as (see e.g. [27, 28])

$$\mathbf{F}_{\text{reaction}} \sim \frac{2}{3} \frac{e^2}{c^2} \frac{d^3 \mathbf{r}}{dt^3} \quad (2)$$

and where  $\mathbf{E}$  and  $\mathbf{B}$  represent the electric and magnetic fields acting on the electron and include the ‘zero-point’ contributions

$$\mathbf{E}_{\text{ZP}}(\mathbf{r}, t) = \frac{1}{(L_x L_y L_z)^{1/2}} \sum_{n_x, n_y, n_z = -\infty}^{+\infty} \sum_{\lambda=1,2} \hat{\mathbf{e}}_{\mathbf{k}_n, \lambda} f_{\mathbf{k}_n, \lambda}(\mathbf{r}, t) \quad (3)$$

$$\mathbf{B}_{\text{ZP}}(\mathbf{r}, t) = \frac{1}{(L_x L_y L_z)^{1/2}} \sum_{n_x, n_y, n_z = -\infty}^{+\infty} \sum_{\lambda=1,2} (\mathbf{k}_n \times \hat{\mathbf{e}}_{\mathbf{k}_n, \lambda}) f_{\mathbf{k}_n, \lambda}(\mathbf{r}, t) \quad (4)$$

with

$$f_{\mathbf{k}_n, \lambda}(\mathbf{r}, t) = a_{\mathbf{k}_n, \lambda} \cos(\mathbf{k}_n \cdot \mathbf{r} - \omega_n t) + b_{\mathbf{k}_n, \lambda} \sin(\mathbf{k}_n \cdot \mathbf{r} - \omega_n t) \quad (5)$$

Here  $L_x, L_y, L_z$  denote the linear dimensions of the system,  $n_x, n_y, n_z$  are relative integers,  $\mathbf{k}_n \equiv 2\pi(\frac{n_x}{L_x}, \frac{n_y}{L_y}, \frac{n_z}{L_z})$ ,  $\omega_n = c|\mathbf{k}_n|$  and the polarization vectors satisfy the conditions  $\mathbf{k}_n \cdot \hat{\mathbf{e}}_{\mathbf{k}_n, \lambda} = 0$  and  $\hat{\mathbf{e}}_{\mathbf{k}_n, \lambda} \cdot \hat{\mathbf{e}}_{\mathbf{k}_n, \lambda'} = 0$  for  $\lambda \neq \lambda'$ . Finally, the coefficients  $a_{\mathbf{k}_n, \lambda}$  and  $b_{\mathbf{k}_n, \lambda}$  in the plane wave expansion represent independent random variables of the type that could be simulated by a random number generator routine with zero mean and second moment distributions

$$\langle a_{\mathbf{k}_n, \lambda}^2 \rangle = \langle b_{\mathbf{k}_n, \lambda}^2 \rangle = 2\pi \hbar \omega_n \quad (6)$$

in order to guarantee a Lorentz-invariant energy spectrum  $\rho_{\text{ZP}}(\omega) = \frac{\hbar \omega^3}{(2\pi c^3)}$ . In this sense, SED could be considered the same Lorentz classical electron theory with new boundary conditions and it is remarkable that numerical simulations [25] lead to electron trajectories that nicely agree with the probability density of the Schrödinger wave equation for the ground state of the hydrogen atom.

Even though many aspects have still to be understood (e.g. the existence of metastable states corresponding to the higher energy levels) we can draw the following conclusion. Usually, Lorentz theory is only considered in connection with the origin of relativity. However, within SED, it also provides interesting insights on the quantum phenomena. To this end, one has simply to replace the vanishing field used to characterize the lowest energy state with a random zero-point field. But, then, this means that we should change the picture of the Lorentz ether. Apparently, it should no longer be thought as a stagnant fluid (for an observer at rest) or as a fluid in laminar motion (for an observer in uniform motion). Rather the ether should resemble a fluid in a chaotic state, a fluid in a state of *turbulent* motion.

---

<sup>2</sup>Davidson [26] argues that the peculiar aspects of quantum mechanics, as embodied in the Schrödinger equation, could be traced back to a statistical description of the radiative reactive force of classical electromagnetism.

This same idea of an underlying turbulent ether is also supported by other arguments. For instance, Maxwell equations can be derived formally as hydrodynamic fluctuations of an incompressible turbulent fluid [29, 30, 31, 32]. As in the original model proposed by Kelvin [33], the energy which is locally stored into the vortical motion becomes a source of elasticity and the fluid resembles an elastic medium that can support the propagation of transverse waves. In this derivation, one starts from the Navier-Stokes or Euler equations for fluid dynamics and splits the full velocity field into average  $\langle v_i \rangle$  and fluctuation component  $v'_i$ . The existence of transverse waves depends crucially on the Reynolds stress tensor  $\tau_{ik} = \langle v'_i v'_k \rangle$  which vanishes for a pure laminar regime and, in this context, could be considered the analog of the stress tensor of elastic media. Notice that, here, one starts from a non-relativistic framework while Maxwell equations and their Lorentz invariance ‘emerge’ from the dynamics of the underlying turbulent fluid.

A similar picture is also suggested by the formal equivalence [34, 35] (velocity potential vs. displacement, velocity vs. distortion, vorticity vs. density of dislocations,...) that can be established between various systems of screw dislocations in an elastic solid and corresponding vortex fields in a liquid. In this way, the phenomenon of turbulence can provide a conceptual transition from fluid dynamics to a different realm of physics, that of elasticity, where the wave speed, that by itself is simply a quantity that remains invariant under changes of the *average* velocity of the fluid, acquires also the meaning of a limiting speed. This is due to the behaviour of the elastic energy of moving dislocations (taken as models for the ordinary ponderable matter) that increases proportionally to  $(1 - v^2/c^2)^{-1/2}$ , see e.g. [36]–[41]. This type of correspondence, between turbulent fluids and elastic media, leads to that intuitive visualization of the relativistic effects which is characteristic of a Lorentzian approach.

Finally, this idea of a turbulent ether is also natural to get in touch with other ‘stochastic’ or ‘hidden-variable’ models of quantum mechanics. For instance, let us consider Nelson’s mechanics. His starting point is that “particles in empty space, or let us say the ether, are subject to Brownian motion” [42]. However, the fundamental nature of the phenomenon requires an ether with vanishingly small friction <sup>3</sup>“for then we could distinguish absolute rest from uniform motion” [42]. In this sense, apparently, the ether should behave as a perfect vacuum. But, then, why there should be a Brownian motion? A solution of this apparent contradiction can be obtained if we use Onsager’s original result [44] on turbulent fluids: in the zero-viscosity limit, i.e. infinite Reynolds number, the fluid velocity field does *not* remain a differentiable function. This irregular behaviour of the underlying ether gives a physical

---

<sup>3</sup>Actually Nelson assumed an exactly zero-friction ether where the diffusion coefficient in the Brownian motion for a particle with mass  $m$  is  $\nu = \hbar/(2m)$ . The case of an infinitesimal friction was studied by Kaloyerou and Vigier [43]. This effectively amounts to the replacement  $\nu \rightarrow \nu e^{-\beta}$  and, by comparing with precision experiments (e.g. the Lamb shift), one finds  $|\beta| \lesssim 10^{-13}$ .

argument to expect that the resulting particle “Brownian motion will not be smooth” [42] and thus to consider the particular form of kinematics which is at the basis of Nelson’s stochastic derivation of the Schrödinger equation.

Analogously, in spite of some differences [45], this idea of a fluid with very irregular and effectively random fluctuations had also been advocated by Bohm and Vigier [46].

On the other hand, it is also true that relativistic effects can be described without ever mentioning the idea of an ether and the methods of stochastic quantization [49, 50] can be introduced as a pure theoretical construct <sup>4</sup>. In this sense, one could adopt Nelson’s words (“I simply do not know whether the things I have been talking about are physics or formalism” [51]) to conclude that the idea of a turbulent ether, although plausible, cannot be demonstrated on the basis of the previous arguments.

Instead, to find definite support, one could look for some unexpected experimental signature, thus coming to our question 2). But what kind of experiment could ever detect a zero-viscosity fluid? Up to now, the implicit assumption made by all authors is that a ‘subquantal’ ether (if any) is so elusive that its existence can only be deduced *indirectly*, i.e. through the deviation of the microsystems from the classical behaviour. However, what about those highly sensitive ‘ether-drift’ experiments that, since the original Michelson-Morley experiment, have deeply influenced our vision of relativity? Do they show any evidence for a non zero effect? Eventually, could a tiny ether-drift represent the manifestation of that fundamental form of noise we have envisaged?

At first sight, this possibility may seem in blatant contradiction with Lorentz transformations. However, this is not necessarily true. In fact, the speed of light in the vacuum, say  $c_\gamma$ , might not coincide *exactly* with the basic parameter  $c$  entering Lorentz transformations, see e.g. Ref.[52]. For instance, as stressed in [53], this could happen in an ‘emergent-gravity’ scenario where, as in our case, one tends to consider the physical vacuum as being not trivially ‘empty’. In this framework, the space-time curvature observed in a gravitational field could represent an effective phenomenon, analogously to a hydrodynamic description of moving fluids on length scales that are much larger than the size of the elementary constituents of the fluid [54, 55, 56]. Thus, although space-time is exactly flat at the very fundamental level, one might be faced with forms of curved ‘acoustic’ metrics in which  $c_\gamma \neq c$  thus opening the possibility of a tiny but non-zero ether drift.

---

<sup>4</sup>Another notable exception is represented by Calogero’s semi-quantitative derivation [47]. This is based on the chaotic structure of many-body classical systems and the long-range nature of the gravitational  $1/r$  potential. As a consequence of these facts, in addition to the standard gravitational effects, every particle should experience locally a stochastic acceleration field (due to the rest of the Universe) which, remarkably, appears to have the right order of magnitude to explain the value of  $\hbar$ . To fill the gap with the idea of an underlying stochastic medium, the interesting connections between Brownian motion and potential theory [48] could be important.

Here we want to emphasize that, in a scenario where one is taking seriously a model of turbulent ether, there might be non trivial modifications in the interpretation of the data. In fact, in the traditional analysis of the ether-drift experiments, the hypothetical, preferred reference frame associated with the ether has always been assumed to occupy a definite, fixed location in space. This induces to search for smooth time modulations of the signal that might be synchronous with the Earth's rotation and its orbital revolution. However, suppose that the ether were indeed similar to a turbulent fluid. On the one hand, this poses the theoretical problem of how to relate the macroscopic motions of the Earth's laboratory (daily rotation, annual orbital revolution,...) to the microscopic measurement of the speed of light inside the optical cavities. On the other hand, from an experimental point of view, it suggests sizeable random fluctuations of the signal that could be erroneously interpreted as a mere instrumental effect. Since the ultimate implications of our continuous flowing in such a medium could be substantial, we believe that it is worth to re-discuss these experiments in some detail by providing the reader with the essential ingredients for their interpretation . After all, other notable examples are known (e.g. the Cosmic Microwave Background Radiation) where, at the beginning, an important physical signal was interpreted as a mere instrumental effect.

In the following, we shall first review in Sect.3 the motivations to re-propose a modern form of Lorentzian relativity, in connection with the emergent-gravity scenario, and in Sect.4 the problem of measuring the speed of light in vacuum optical cavities placed on the Earth' surface. More technical aspects will be discussed in Sects.5 and 6. These aspects are essential to fully appreciate the puzzle posed by the present experimental situation: is the observed signal a spurious instrumental effect or a non-trivial physical manifestation of an underlying stochastic ether? Finally, Sect.7 will contain a summary and our conclusions with an outlook on the planned experimental improvements.

### 3. Lorentzian relativity and the emergent-gravity scenario

There is a basic controversy about relativity that dates back to its origin and concerns the interpretation of Lorentz transformations. Do they originate from the *relative* motion of any pair of observers  $S'$  and  $S''$ , as in Einstein's special relativity, or from the *individual* motion of each observer with respect to a hypothetical preferred reference frame  $\Sigma$  as in the Lorentz-Poincaré formulation ? As pointed out by several authors, see e.g. [57, 58, 59, 60], there is no simple answer to this question. In fact, Lorentz transformations have a group structure. Thus if  $S'$  were individually related to  $\Sigma$  by a Lorentz transformation with dimensionless velocity parameter  $\beta' = v'/c$  and  $S''$  were related to  $\Sigma$  by a Lorentz transformation with parameter  $\beta'' = v''/c$ , the two frames  $S'$  and  $S''$  would also be mutually connected by a

Lorentz transformation with relative velocity parameter

$$\beta_{\text{rel}} = \frac{\beta' - \beta''}{1 - \beta'\beta''} \equiv \frac{v_{\text{rel}}}{c} \quad (7)$$

(we restrict for simplicity to one-dimensional motions). This leads to a substantial quantitative equivalence of the two formulations for most standard experimental tests where one just compares the relative measurements of a pair of observers <sup>5</sup>.

But now, what about ether-drift experiments ? In this context, the basic issue concerns the value of  $c_\gamma$ , the speed of light in the vacuum. Does it coincide *exactly* [52] with the basic parameter  $c$  entering Lorentz transformations? Up to now, the apparent failure of all attempts to measure the individual  $\beta'$ ,  $\beta''$ ,... has been interpreted as an experimental indication for  $c_\gamma = c$  and this has provided, probably, the main motivation for the wide preference given today to special relativity.

However, if  $c_\gamma = c$ , also in the Lorentz-Poincaré formulation relativistic effects conspire to make undetectable a state of absolute motion in Michelson-Morley experiments. Therefore, it is only the conceptual relevance of retaining a physical substratum in the theory that may induce to re-discover the potentially profound implications of the ‘Lorentzian’ approach and explore scenarios with tiny effects producing  $c_\gamma \neq c$ . To this end, as anticipated, one could consider the emergent-gravity scenario [54, 55] where the space-time curvature observed in a gravitational field becomes an effective phenomenon, analogously to a hydrodynamic description of moving fluids.

In this perspective, local distortions of the underlying ethereal medium could produce local modifications of the basic space-time units which are known, see e.g. [62, 63], to represent an alternative way to generate an effective non-trivial curvature. This point of view has been vividly represented by K. Thorne in one of his books [64]: ”Is space-time really curved ? Isn’t conceivable that space-time is actually flat, but clocks and rulers with which we measure it, and which we regard as perfect, are actually rubbery ? Might not even the most perfect of clocks slow down or speed up and the most perfect of rulers shrink or expand, as we move them from point to point and change their orientations ? Would not such distortions of our clocks and rulers make a truly flat space-time appear to be curved ? Yes”.

By following this type of interpretation, one could first consider a simplest two-parameter scheme [56] in which there are simultaneous re-scalings of i) any mass  $m$  (and binding energy)

---

<sup>5</sup>A clean and authoritative statement of this substantial experimental equivalence could already be found in Ehrenfest’s inaugural lecture [61] held in Leyden on December 4th, 1912 ”So, we see that the ether-less theory of Einstein demands exactly the same here as the ether theory of Lorentz. It is, in fact, because of this circumstance, that according to the Einsteinian theory an observer must observe the exact same contractions, changes of rates, etc. in the measuring rods, clocks etc. moving with respect to him as according to the Lorentzian theory. And let it be said here right away in all generality. As a matter of principle, there is no experimentum crucis between these two theories”.

and of ii) the velocity of light in the vacuum as with a non-trivial vacuum refractive index, i.e.

$$m \rightarrow \hat{m}(x) \qquad c_\gamma \rightarrow \frac{c}{\mathcal{N}(x)} \qquad (8)$$

In this case, the physical units would also be rescaled

$$\hat{t}(x) = \frac{\hbar}{\hat{m}(x)c^2} \equiv \lambda(x)t \qquad \hat{l}(x) = \frac{\hbar}{\hat{m}(x)c} \equiv \lambda(x)l \qquad (9)$$

producing the effective metric structure ( $A = c^2 \frac{\lambda^2}{\mathcal{N}^2}$  and  $B = \lambda^2$ )

$$g_{\mu\nu} = \text{diag}(A, -B, -B, -B) \qquad (10)$$

whose consistency with experiments requires the weak-field identification with the Newtonian potential

$$\mathcal{N} \sim 1 + 2\frac{|U_N|}{c^2} \qquad \lambda \sim 1 + \frac{|U_N|}{c^2} \qquad (11)$$

Then, more complicated metrics with off-diagonal elements  $g_{0i} \neq 0$  and  $g_{ij} \neq 0$  can be obtained by applying boosts and rotations to Eq.(10) thus basically reproducing the picture of the curvature effects in a moving fluid. In this way, one is driven to consider the possibility of a non-zero (but admittedly extremely small) light anisotropy that could be measured in the present generation of precise ether-drift experiments. This other part will be discussed in the following section.

## 4. The speed of light in the vacuum

After having discussed why gravity might induce local modifications of the basic space-time units, let us now consider the problem of measuring the speed of light. On a general ground, to determine speed as (distance moved)/(time taken), one must first choose some standards of distance and time. Since different choices can give different answers, we shall adopt in the following the point of view of special relativity where the speed of light in the vacuum  $c_\gamma$ , when measured in an inertial frame, coincides with the basic parameter  $c$  that enters Lorentz transformations. However, inertial frames are just an idealization. Therefore the appropriate realization is to assume *local* standards of distance and time such that the identification  $c_\gamma = c$  holds as an asymptotic relation in the physical conditions which are as close as possible to an inertial frame, i.e. *in a freely falling frame* (at least by restricting to a space-time region small enough that tidal effects of the external gravitational potential  $U_{\text{ext}}(x)$  can be ignored). This is essential to obtain an operative definition of the otherwise unknown parameter  $c$ . At the same time, the consistency of this scheme can be checked by comparing with experiments.

In fact, with these premises, light propagation for an observer  $S'$  sitting on the Earth's surface can be described with increasing degrees of approximations [53]:

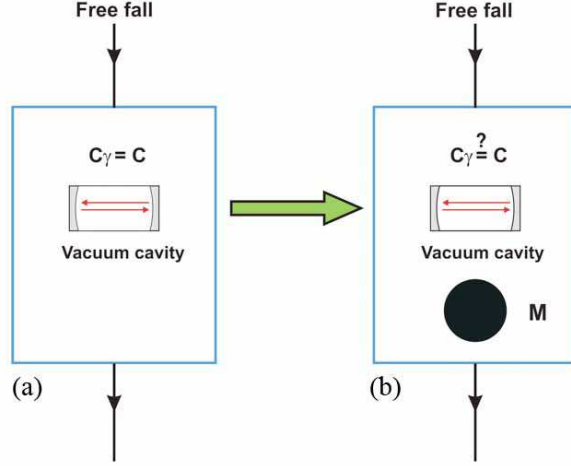

Figure 1: A pictorial representation of the effect of a heavy mass  $M$  carried on board of a freely-falling system, case (b). With respect to case (a), in a flat-space picture of gravity, the mass  $M$  modifies the effective, local space-time structure by re-scaling the physical units  $(dx, dy, dz, dt) \rightarrow (d\hat{x}, d\hat{y}, d\hat{z}, d\hat{t})$  and introducing a non-trivial refractive index  $\mathcal{N} \neq 1$  so that now  $c_\gamma \neq c$ .

i)  $S'$  is considered a freely falling frame. This amounts to assume  $c_\gamma = c$  so that, given two events which, in terms of the local space-time units of  $S'$ , differ by  $(dx, dy, dz, dt)$ , light propagation is described by the condition (ff='free-fall')

$$(ds^2)_{\text{ff}} = c^2 dt^2 - (dx^2 + dy^2 + dz^2) = 0 \quad (12)$$

ii) Now, is really the Earth a freely-falling frame? To a closer look, in fact, an observer  $S'$  placed on the Earth's surface can only be considered a freely-falling frame up to the presence of the Earth's gravitational field. Its inclusion leads to tiny deviations from the standard Eq.(12). These can be estimated by considering  $S'$  as a freely-falling frame (in the same external gravitational field described by  $U_{\text{ext}}(x)$ ) that however is also carrying on board a heavy object of mass  $M$  (the Earth's mass itself) that affects the effective local space-time structure (see Fig.1). To derive the required correction, let us again denote by  $(dx, dy, dz, dt)$  the local space-time units of the freely-falling observer  $S'$  in the limit  $M = 0$  and by  $\delta U$  the extra Newtonian potential produced by the heavy mass  $M$  at the experimental set up where one wants to describe light propagation. From Eqs.(10) and (11), in an emergent-gravity scenario, light propagation for the  $S'$  observer can then be described by the condition [53]

$$(ds^2)_{\delta U} = \frac{c^2 d\hat{t}^2}{\mathcal{N}^2} - (d\hat{x}^2 + d\hat{y}^2 + d\hat{z}^2) = 0 \quad (13)$$



where, to first order in  $\delta U$ , the space-time units  $(d\hat{x}, d\hat{y}, d\hat{z}, d\hat{t})$  are related to the corresponding ones  $(dx, dy, dz, dt)$  for  $\delta U = 0$  through an overall re-scaling factor

$$\lambda = 1 + \frac{|\delta U|}{c^2} \quad (14)$$

and we have also introduced the vacuum refractive index

$$\mathcal{N} = 1 + 2\frac{|\delta U|}{c^2} \quad (15)$$

Therefore, to this order, light is formally described as in General Relativity where one finds the weak-field, isotropic form of the metric

$$(ds^2)_{\text{GR}} = c^2 dT^2 \left(1 - 2\frac{|U_N|}{c^2}\right) - (dX^2 + dY^2 + dZ^2) \left(1 + 2\frac{|U_N|}{c^2}\right) \equiv c^2 d\tau^2 - dl^2 \quad (16)$$

In Eq.(16)  $U_N$  denotes the Newtonian potential and  $(dT, dX, dY, dZ)$  arbitrary coordinates defined for  $U_N = 0$ . Finally,  $d\tau$  and  $dl$  denote the elements of proper time and proper length in terms of which, in General Relativity, one would again deduce from  $ds^2 = 0$  the same universal value  $c = \frac{dl}{d\tau}$ . This is the basic difference with Eqs.(13)-(15) where the physical unit of length is  $\sqrt{d\hat{x}^2 + d\hat{y}^2 + d\hat{z}^2}$ , the physical unit of time is  $d\hat{t}$  and instead a non-trivial refractive index  $\mathcal{N}$  is introduced. For an observer placed on the Earth's surface, its value is

$$\mathcal{N} - 1 \sim \frac{2G_N M}{c^2 R} \sim 1.4 \cdot 10^{-9} \quad (17)$$

$M$  and  $R$  being respectively the Earth's mass and radius.

iii) Differently from General Relativity, in a flat-space interpretation with re-scaled units  $(d\hat{x}, d\hat{y}, d\hat{z}, d\hat{t})$  and  $\mathcal{N} \neq 1$ , the speed of light in the vacuum  $c_\gamma$  no longer coincides with the parameter  $c$  entering Lorentz transformations. Therefore, as a general consequence of Lorentz transformations, an isotropic propagation as in Eq.(13) can only be valid for a special state of motion of the Earth's laboratory. This provides the operative definition of a preferred reference frame  $\Sigma$  while for a non-zero relative velocity  $\mathbf{V}$  one expects off diagonal elements  $g_{0i} \neq 0$  in the effective metric and a tiny light anisotropy. As shown in Ref.[53], to first order in both  $(\mathcal{N} - 1)$  and  $V/c$  one finds

$$g_{0i} \sim 2(\mathcal{N} - 1) \frac{V_i}{c} \quad (18)$$

These off diagonal elements can be imagined as being due to a directional polarization of the vacuum induced by the now moving Earth's gravitational field and express the general property [65] that any metric, locally, can always be brought into diagonal form by suitable rotations and boosts. In this way, by introducing  $\beta = V/c$ ,  $\kappa = (\mathcal{N}^2 - 1)$  and the angle  $\theta$  between  $\mathbf{V}$  and the direction of light propagation, one finds, to  $\mathcal{O}(\kappa)$  and  $\mathcal{O}(\beta^2)$ , the one-way velocity [53]

$$c_\gamma(\theta) = \frac{c}{\mathcal{N}} \left[ 1 - \kappa\beta \cos\theta - \frac{\kappa}{2}\beta^2(1 + \cos^2\theta) \right] \quad (19)$$

and a two-way velocity of light

$$\begin{aligned}\bar{c}_\gamma(\theta) &= \frac{2c_\gamma(\theta)c_\gamma(\pi + \theta)}{c_\gamma(\theta) + c_\gamma(\pi + \theta)} \\ &\sim \frac{c}{\mathcal{N}} \left[ 1 - \beta^2 \left( \kappa - \frac{\kappa}{2} \sin^2 \theta \right) \right]\end{aligned}\quad (20)$$

This allows to define the RMS [66, 67] anisotropy parameter  $\mathcal{B}$  through the relation

$$\frac{\Delta\bar{c}_\theta}{c} = \frac{\bar{c}_\gamma(\pi/2 + \theta) - \bar{c}_\gamma(\theta)}{\langle \bar{c}_\gamma \rangle} \sim \mathcal{B} \frac{V^2}{c^2} \cos(2\theta) \quad (21)$$

with

$$|\mathcal{B}| \sim \frac{\kappa}{2} \sim \mathcal{N} - 1 \quad (22)$$

From the previous analysis, by replacing the value of the refractive index Eq.(17) and adopting, as a rough order of magnitude, the typical value of most cosmic motions  $V \sim 300$  km/s<sup>6</sup>, one expects a tiny fractional anisotropy

$$\frac{\langle \Delta\bar{c}_\theta \rangle}{c} \sim |\mathcal{B}| \frac{V^2}{c^2} = \mathcal{O}(10^{-15}) \quad (23)$$

that could finally be detected in the present, precise ether-drift experiments. These experiments will be discussed in the following section.

## 5. Ether-drift experiments and stochastic ether

In the present ether-drift experiments one measures the frequency shift, i.e. the beat signal,  $\Delta\nu$  of two cavity-stabilized lasers (see Fig.2) whose definite non-zero value would provide a direct measure of an anisotropy of the velocity of light [68]. In this framework, the possible time modulation of the signal that might be induced by the Earth's rotation (and its orbital revolution) has always represented a crucial ingredient for the analysis of the data. For instance, let us consider the relative frequency shift for the experiment of Ref.[69]. Here the basic concept of light anisotropy Eq.(21) as a second-harmonic effect leads to the parametrization

$$\frac{\Delta\bar{c}_\theta(t)}{c} = \frac{\Delta\nu(t)}{\nu_0} = S(t) \sin 2\omega_{\text{rot}}t + C(t) \cos 2\omega_{\text{rot}}t \quad (24)$$

where  $\nu_0$  indicates the reference frequency of the two resonators and  $\omega_{\text{rot}}$  is the rotation frequency of one resonator with respect to the other which is kept fixed in the laboratory and oriented north-south. If one assumes the picture of a *fixed* preferred frame  $\Sigma$  then, for short-time observations of 1-2 days, the time dependence of a hypothetical physical signal can only

---

<sup>6</sup>For instance, from the motion of the Solar System within the Galaxy, or with respect to the centroid of the Local Group or with respect to the CMBR, one gets respectively  $V \sim 240, 320, 370$  km/s.

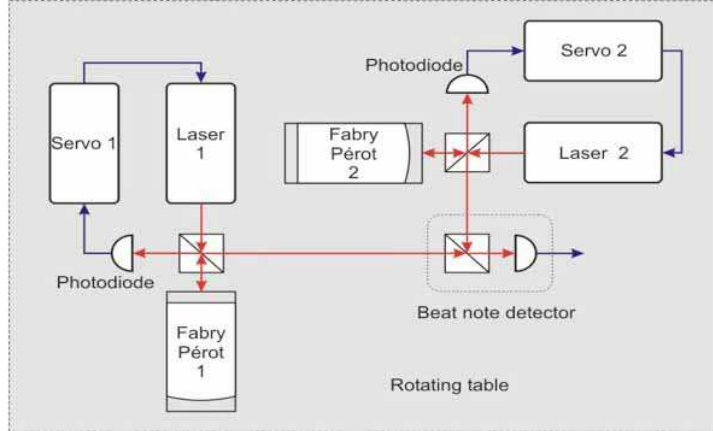

Figure 2: *The scheme of a modern ether-drift experiment. The frequencies  $\nu_1$  and  $\nu_2$  of the signals from the two Fabry-Pérot resonators are compared in the beat note detector that provides the frequency shift  $\Delta\nu = \nu_1 - \nu_2$ . In this picture, the apparatus is fully symmetric. On the other hand, in Ref.[69] only one of the two resonators was rotating while the other was kept fixed in the laboratory and oriented north-south.*

be due to (the variations of the projection of the Earth's velocity  $\mathbf{V}$  in the interferometer's plane caused by) the Earth's rotation. In this case, the two functions  $S(t)$  and  $C(t)$  admit the simplest Fourier expansion [69] ( $\tau = \omega_{\text{sid}}t$  is the sidereal time of the observation in degrees)

$$S(t) = S_0 + S_{s1} \sin \tau + S_{c1} \cos \tau + S_{s2} \sin(2\tau) + S_{c2} \cos(2\tau) \quad (25)$$

$$C(t) = C_0 + C_{s1} \sin \tau + C_{c1} \cos \tau + C_{s2} \sin(2\tau) + C_{c2} \cos(2\tau) \quad (26)$$

with *time-independent*  $C_k$  and  $S_k$  Fourier coefficients. Thus, by accepting this theoretical framework, it becomes natural to average the various  $C_k$  and  $S_k$  obtained from fits performed during a 1-2 day observation period. By further averaging over many short-period experimental sessions, the data support the general conclusion [70, 71, 72] that, although the typical instantaneous  $S(t)$  and  $C(t)$  are  $\mathcal{O}(10^{-15})$ , the global averages  $(C_k)^{\text{avg}}$  and  $(S_k)^{\text{avg}}$  for the Fourier coefficients are much smaller, at the level  $\mathcal{O}(10^{-17})$ , and, with them, the derived parameters entering the phenomenological SME [73] and RMS [66, 67] models.

However, there might be different types of ether-drift where the straightforward parameterizations Eqs.(25), (26) and the associated averaging procedures are *not* allowed. Therefore we believe that, before assuming any definite theoretical scenario, one should first ask: if light were really propagating in a physical medium, an ether, and not in a trivial empty vacuum, how should the motion of (or in) this medium be described? Namely, could this relative

motion exhibit variations that are *not* only due to known effects as the Earth's rotation and orbital revolution?

The point is that, by representing the physical vacuum as a fluid, the standard assumption of smooth sinusoidal variations of the signal, associated with the Earth's rotation (and its orbital revolution), corresponds to assume the conditions of a pure laminar flow associated with simple regular motions. Instead, by adopting the model of an underlying turbulent medium there might be other forms of time modulations. In this alternative scenario, the same basic experimental data might admit a different interpretation and a definite instantaneous signal  $\Delta\nu(t) \neq 0$  could become consistent with  $(C_k)^{\text{avg}} \sim (S_k)^{\text{avg}} \sim 0$ .

To exploit the possible implications, let us first recall the general aspects of any turbulent flow. This is characterized by extremely irregular variations of the velocity, with time at each point and between different points at the same instant, due to the formation of eddies [74]. For this reason, the velocity continually fluctuates about some mean value and the amplitude of these variations is *not* small in comparison with the mean velocity itself. The time dependence of a typical turbulent velocity field can be expressed as [74]

$$\mathbf{v}(x, y, z, t) = \sum_{p_1 p_2 \dots p_n} \mathbf{a}_{p_1 p_2 \dots p_n}(x, y, z) \exp(-i \sum_{j=1}^n p_j \phi_j) \quad (27)$$

where the quantities  $\phi_j = \omega_j t + \beta_j$  vary with time according to fundamental frequencies  $\omega_j$  and depend on some initial phases  $\beta_j$ . As the Reynolds number  $\mathcal{R}$  increases, the total number  $n$  of  $\omega_j$  and  $\beta_j$  increases thus suggesting a sequence where laminar flow first becomes periodic, then quasi-periodic and finally highly turbulent. In this limit, where  $\mathcal{R} \rightarrow \infty$ , the required number of frequencies diverges so that the theory of such a turbulent flow must be a statistical theory.

Now, as anticipated in Sect.2, there are arguments to consider the limit of an ether with vanishingly small viscosity where, indeed, the relevant Reynolds numbers should become infinitely large in most regimes. In this case, one is faced precisely with the limit of a fully developed turbulence where the temporal analysis of the flow requires an extremely large number of frequencies and the physical vacuum behaves as a *stochastic* medium. Thus random fluctuations of the signal, superposed on the smooth sinusoidal behaviour associated with the Earth's rotation (and orbital revolution), would produce deviations of the time dependent functions  $S(t)$  and  $C(t)$  from the simple structure in Eqs.(25) and (26) and an effective temporal dependence of the fitted  $C_k = C_k(t)$  and  $S_k = S_k(t)$ . In this situation, due to the strong cancelations occurring in vectorial quantities when dealing with stochastic signals, one could easily get vanishing global inter-session averages

$$(C_k)^{\text{avg}} \sim (S_k)^{\text{avg}} \sim 0 \quad (28)$$

Nevertheless, as it happens with the phenomena affected by random fluctuations, the average quadratic amplitude of the signal could still be preserved. To this end, let us re-write Eq.(24) as

$$\frac{\Delta\bar{c}_\theta(t)}{c} = \frac{\Delta\nu(t)}{\nu_0} = A(t) \cos(2\omega_{\text{rot}}t - 2\theta_0(t)) \quad (29)$$

where

$$C(t) = A(t) \cos 2\theta_0(t) \quad S(t) = A(t) \sin 2\theta_0(t) \quad (30)$$

so that

$$A(t) = \sqrt{S^2(t) + C^2(t)} \quad (31)$$

Here  $\theta_0(t)$  represents the instantaneous direction of a hypothetical ether-drift effect in the x-y plane of the interferometer (counted by convention from North through East so that North is  $\theta_0 = 0$  and East is  $\theta_0 = \pi/2$ ). By also introducing the magnitude  $v = v(t)$  of the *projection* of the full  $\mathbf{V}$ , such that

$$v_x(t) = v(t) \sin \theta_0(t) \quad v_y(t) = v(t) \cos \theta_0(t) \quad (32)$$

and adopting the same notations as in Eq.(23), we obtain the theoretical relations [53]

$$A_{\text{th}}(t) = \frac{1}{2}|\mathcal{B}|\frac{v^2(t)}{c^2} \quad (33)$$

and

$$C_{\text{th}}(t) = \frac{1}{2}|\mathcal{B}|\frac{v_y^2(t) - v_x^2(t)}{c^2} \quad S_{\text{th}}(t) = \frac{1}{2}|\mathcal{B}|\frac{2v_x(t)v_y(t)}{c^2} \quad (34)$$

In this way, in a stochastic ether, the positive-definite amplitude  $A(t)$  of the signal will have a definite non-zero average value  $\langle A \rangle$  and this can well coexist with  $(C_k)^{\text{avg}} \sim (S_k)^{\text{avg}} \sim 0$ . Physical conclusions will then require to first compare the measured value of  $\langle A \rangle$  with the short-term, stability limits of the individual optical resonators and then with the theoretical expectation (33).

## 6. Instrumental effects or fundamental noise?

To provide evidence that indeed, in ether-drift experiments, we might be faced with a form of fundamental noise from an underlying stochastic ether, the present, most precise experiments [71, 75] were considered in Ref.[53]. In the experimental apparatus of Ref.[75], to minimize all sources of systematic asymmetry, the two optical cavities were obtained from the same monolithic block of ULE (Ultra Low Expansion material). In these conditions, due to sophisticated electronics and temperature controls, the short-term (about 40 seconds) stability limits for the individual optical cavities are extremely high. Namely, for the non-rotating set up, by taking into account various systematic effects, one deduces stabilities  $(\delta\nu)_1 \sim (\delta\nu)_2 \sim \pm 0.05$

Hz for the individual cavities 1 and 2 and thus about  $\pm 2 \cdot 10^{-16}$  in units of a laser frequency  $\nu_0 = 2.82 \cdot 10^{14}$  Hz. This is of the same order of the *average* frequency shift between the two resonators, say  $(\Delta\nu)^{\text{avg}} \sim \pm 0.06$  Hz, when averaging the signal over a very large number of temporal sequences (see their Fig.9b).

However, the magnitude of the *instantaneous* frequency shift  $\Delta\nu(t)$  is much larger, say  $\pm 1$  Hz (see their Fig.9a), and so far has been interpreted as a spurious instrumental effect. To check this interpretation, we observe that, in the absence of any genuine physical signal, the frequency shift between the two resonators should exhibit the same typical instabilities  $(\delta\nu)_1$  and  $(\delta\nu)_2$  of the individual resonators and thus, for short-time observations, should be at the same level  $\pm 2 \cdot 10^{-16}$ . Instead, for the same non-rotating set up, the minimum noise in the frequency shift  $\Delta\nu$  was found about 10 times bigger, namely  $1.9 \cdot 10^{-15}$  (see Fig.8 of Ref.[75]). Also the trend of this form of noise in the beat signal, as function of the averaging time, is different from the corresponding one observed in the individual resonators thus suggesting that the two types of noise might have different origin.

The authors tend to interpret this relatively large beat signal as cavity thermal noise and refer to [76]. However, this interpretation is not so obvious since the typical disturbances  $(\delta\nu)_1$  and  $(\delta\nu)_2$  in the *individual* cavities were reduced to a considerably lower level.

For a quantitative estimate of the amplitude  $A(t)$  of the signal we can consider the more recent paper [72] of the same authors. The physical second-harmonic part of the signal that corresponds to an ether-drift effect, from their Eq.(1), can be expressed as <sup>7</sup>

$$\left(\frac{\Delta\nu(t)}{\nu_0}\right)^{\text{physical}} = 2B(t) \sin 2\omega_{\text{rot}}t + 2C(t) \cos 2\omega_{\text{rot}}t \equiv A^{\text{symm}}(t) \cos(2\omega_{\text{rot}}t - 2\theta_0(t)) \quad (35)$$

where

$$A^{\text{symm}}(t) = 2\sqrt{B^2(t) + C^2(t)} \quad (36)$$

Now the data of Ref.[72] confirm the above mentioned trend with average values  $\langle B \rangle$  and  $\langle C \rangle$  which are much smaller than their typical instantaneous values since one finds (see their Fig.3)

$$\langle B \rangle \sim \langle C \rangle \sim \mathcal{O}(10^{-17}) \quad (37)$$

Therefore the quadratic average values  $\langle B^2 \rangle$  and  $\langle C^2 \rangle$  are essentially determined by the variances  $\sigma_B \sim 7.5 \cdot 10^{-16}$  and  $\sigma_C \sim 6.1 \cdot 10^{-16}$  [72]. In this way, we obtain the experimental value

$$\langle A_{\text{exp}}^{\text{symm}} \rangle \sim 2\sqrt{\sigma_B^2 + \sigma_C^2} \sim 1.9 \cdot 10^{-15} \quad (38)$$

---

<sup>7</sup>For an easier comparison, we maintain the notations of Ref.[72] where  $B(t)$  is used to denote the same amplitude  $S(t)$  introduced before in Eq.(24) and the overall factor of 2 takes into account the differences with respect to Eq.(24) introduced by a fully symmetric apparatus.

in good agreement with our theoretical expectation from Eqs.(17), (22) and (33) for the average Earth's velocity of most cosmic motions  $\sqrt{\langle v^2 \rangle} \sim 300$  km/s

$$\langle A_{\text{th}}^{\text{symm}} \rangle = 2\langle A_{\text{th}} \rangle = |\mathcal{B}| \frac{\langle v^2 \rangle}{c^2} \sim 1.4 \cdot 10^{-15} \frac{\langle v^2 \rangle}{(300 \text{ km/s})^2} \quad (39)$$

Similar conclusions can be obtained from the other experiment of Ref.[71] where the stability of the individual resonators is at the same level of a few  $10^{-16}$ . Nevertheless, the measured  $C(t)$  and  $S(t) \equiv B(t)$  entering the beat signal span the whole range  $\pm 1.2 \cdot 10^{-15}$  (see their Fig.4a) and are again interpreted in terms of a thermal noise of the individual cavities. Thus, in the present two most precise ether-drift experiments, the average amplitude of the signal is about 4-5 times larger than the short-term stability of the individual resonators and its measured value  $\langle A \rangle = \mathcal{O}(10^{-15})$  is completely consistent with our theoretical expectations.

Finally, as an additional check, a comparison with a previous experiment [77] operating in the cryogenic regime was also performed in Ref.[53]. Again, by restricting to the variable part of the signal which is less affected by spurious systematic effects (see Ref.[53]), the average amplitude was found  $\mathcal{O}(10^{-15})$ . Thus this stable value of about  $10^{-15}$  found in all experiments is unlike to represent a spurious instrumental artifact of the individual optical cavities of the type discussed in Ref.[76]. In fact, the estimate of Ref.[76] is based on the fluctuation-dissipation theorem, and therefore there is no reason that both room temperature and cryogenic experiments exhibit the same instrumental noise. This argument confirms that, at present, there is a basic ambiguity in the interpretation of the experimental data. The standard interpretation in terms of spurious instrumental effects of the individual optical cavities is by no means unique and the observed signal could also represent a fundamental noise associated with the underlying stochastic ether.

The puzzle, however, should be definitely solved in a next future. In fact, the authors of Ref.[71] are starting to upgrade their apparatus with cryogenically cooled sapphire optical cavities [78]. This should improve the short-term stability of the individual resonators by about two orders of magnitude (say well below the  $10^{-17}$  level). In these new experimental conditions, the persistence of an average amplitude  $\langle A \rangle = \mathcal{O}(10^{-15})$  (i.e. about 100 times larger) would represent an unambiguous evidence for the type of random vacuum we have been considering.

## 7. Summary and conclusions

In this paper, by following the authors of Ref.[1], we have re-considered the idea of an 'objective randomness' in nature as a basic property, independent of any experimental accuracy of the observations or limited knowledge of initial conditions. The interesting aspect is that, besides being responsible for the observed quantum behaviour, this might introduce a weak,

residual form of noise which is intrinsic to natural phenomena and could be important for the emergence of complexity at higher physical levels, as suggested by both theoretical and phenomenological evidence.

By trying to implement this idea in a definite dynamical framework, and adopting Stochastic Electro Dynamics as a heuristic model, we have been driven to the idea of the vacuum as an underlying turbulent ether which is deep-rooted into the basic foundational aspects of *both* quantum physics and relativity. Thus, by searching for experimental tests of this scenario, we have concentrated on the modern ether-drift experiments. Our analysis of the most precise experiments (operating both at room temperature and in the cryogenic regime) shows that, at present, there is some ambiguity in the interpretation of the data. In fact, the average amplitude of the beat signal between the two resonators has precisely the magnitude expected, in a ‘Lorentzian’ form of relativity, from an underlying stochastic ether and, as such, might not be a spurious instrumental effect but the manifestation of that fundamental form of noise we have envisaged.

This puzzle, however, should be definitely solved in a next future with the use of new cryogenically cooled optical cavities whose individual stability should improve by about two orders of magnitude. In these new experimental conditions, the persistence of the present amplitude would represent an unambiguous evidence for the type of random vacuum we have been considering. Namely, this would turn out to be similar to a polarizable medium, responsible for the apparent curvature effects seen in a gravitational field and, at the same time, a stochastic medium, similar to a zero-viscosity fluid in a turbulent state of motion, responsible for the observed strong random fluctuations of the signal. All together, the situation might resemble the discovery of the Cosmic Microwave Background Radiation that, at the beginning, was also interpreted as a mere instrumental effect.

Of course, a long series of steps will further be needed to explore the ultimate implications of such new possible framework. For instance, a confirmation of our prediction means that, in agreement with the intuitive notion of an ‘ether wind’, our continuous flowing in the physical vacuum produces an infinitesimal energy-momentum flux. Therefore, after its unambiguous detection ‘in vacuum’, in the completely controlled conditions of the announced, new generation of cryogenic experiments, one might also consider different tests. For instance, ether-drift experiments where cavities are filled by different forms of matter [79, 80] that represent a useful, complementary tool to study small deviations from exact Lorentz invariance. The combined informations from this set of observations of the characteristics of the signal (time modulations, intensity, spatial coherence,...) will be crucial to understand if this tiny effect, by exposing all physical systems to an energy flux, can induce the spontaneous generation of order which is important for the emergence of complexity.

### **Acknowledgments**



We thank L.Pappalardo for useful discussions and collaboration.

## References

- [1] P. Allegrini, M. Giuntoli, P. Grigolini and B. J. West, *Chaos, Solitons and Fractals*, **20** (2004) 11.
- [2] F. Caruso, S.F. Huelga, M.B. Plenio, *Phys. Rev. Lett.* **105** (2010) 190501; H. Lee et al., *Science* **316** (2007) 1462.
- [3] D. Frenkel, *Nature* **443** (2006) 641.
- [4] R. Mantegna and B. Spagnolo, *Phys. Rev. Lett.* **76** (1996) 563.
- [5] L. Gammaitoni, P. Hänggi, P. Jung and F. Marchesoni, *Rev. Mod. Phys.* **70** (1998) 223288.
- [6] P. Hänggi and F. Marchesoni Eds., *Stochastic Systems: From Randomness to Complexity*, *Physica A* **325** (2003) 1.
- [7] C.Beck and E.G.D.Cohen, *Physica A* **322** (2003) 267.
- [8] C.Beck and E.G.D.Cohen, *Phys. Rev. E* **72** (2005) 056133.
- [9] C. Tsallis, *J. Stat. Phys.* **52** (1988) 479
- [10] C.Tsallis, *Introduction to Nonextensive Statistical Mechanics. Approaching a Complex World*, Springer (2009).
- [11] A. Bassi and G. C. Ghirardi, *Phys. Rep.* **379** (2003) 257.
- [12] G. C. Ghirardi, A. Rimini and T. Weber, *Phys. Rev. D* **34** (1986) 470.
- [13] L. Fritsche and M. Haugk, *Stochastic Foundations of Quantum Mechanics and the Origin of Particle Spin*, arXiv:0912.3442 [physics.gen-ph]
- [14] T. H. Boyer, *Phys. Rev.* **182** (1969) 1374; *ibidem* **186** (1969) 1304.
- [15] T. W. Marshall, *Proc. R. Soc. A* **276** (1963) 475.
- [16] T. W. Marshall, *Proc. Cambridge Philos. Soc.* **61** (1965) 537.
- [17] T. H. Boyer, *Phys. Rev. D* **11** (1975) 809.
- [18] L. de la Peña and A. M. Cetto, *The Quantum Dice - An Introduction to Stochastic Electrodynamics*, Kluwer Academic Publ., Dordrecht 1996.

- [19] B. Haisch, A. Rueda and Y. Dobyns, *Annalen der Physik* **10** (2001) 393.
- [20] E. Nelson, *Quantum Fluctuations*, Princeton University Press 1985, page 65.
- [21] M. P. Davidson, *Stochastic Models of Quantum Mechanics - A Perspective*, arXiv:quant-ph/0610046.
- [22] H. E. Puthoff, *Phys. Rev. D* **35** (1987) 3266.
- [23] L. de la Peña and A. M. Cetto, Contribution from stochastic electrodynamics to the understanding of quantum mechanics, arXiv:quant-ph/0501011.
- [24] P. A. M. Dirac, *Proc. R. Soc. A* **167** (1938) 148.
- [25] D. C. Cole and Y. Zou, *Phys. Lett. A* **317** (2003) 14.
- [26] M. Davidson, *J. Math. Phys.* **20** (1979) 1865.
- [27] W. Panofsky and M. Phillips, *Classical electricity and Magnetism*, Addison-Wesley Co. Inc., Reading Massachusetts, 1955, Chapt. 20.
- [28] F. Rohrlich, *Phys. Lett. A* **283** (2001) 276.
- [29] O. V. Troshkin, *Physica A* **168** (1990) 881.
- [30] H. Marmanis, *Physics of Fluids* **10** (1998) 1428.
- [31] H. E. Puthoff, Linearized turbulent flow as an analog model for linearized General Relativity, arXiv:0808.3401 [physics.gen-ph].
- [32] T. Tsankov, *Classical Electrodynamics and the Turbulent Aether Hypothesis*, Preprint February 2009.
- [33] E. T. Whittaker, *A history of the Theories of Aether and Electricity*, Dover Publications, Inc. New York 1989.
- [34] M. J. Marcinkowski, *Physica Status Solidi* **152B** (1989) 9.
- [35] A. M. Kosevic, *The Crystal Lattice: Phonons, Solitons, Superlattices*, Wiley-VCH Verlag GmbH and Co. KGaA, Weinheim 2005, pp. 237-238.
- [36] C. F. Frank, *Proc. Phys. Soc. A* **62** (1949) 131.
- [37] G. I. Taylor, *Proc. R. Soc. A* **145** (1934) 362.
- [38] J. D. Eshelby, *Proc. Phys. Soc. A* **62** (1949) 307.

- [39] H. Günther, *Physica Status Solidi* **149** (1988) 104.
- [40] A. Unzicker, What can Physics learn from Continuum Mechanics?, arXiv:gr-qc/0011064.
- [41] C. I. Christov, *Math. Comput. Simul.* **74** (2007) 93.
- [42] E. Nelson, *Phys. Rev.* **150** (1966) 1079.
- [43] P. N. Kaloyerou and J. P. Vigièr, *Phys. Lett. A* **130** (1988) 260.
- [44] L. Onsager, *Nuovo Cimento, Suppl.* **6** (1949) 279.
- [45] D. Bohm and B. J. Hiley, *Phys. Rep.* **172** (1989) 93.
- [46] D. Bohm and J. P. Vigièr, *Phys. Rev.* **96** (1954) 208.
- [47] F. Calogero, *Phys. Lett. A* **228** (1997) 335.
- [48] A. W. Knap, *Journ. Math. Appl.* **12** (1965) 328.
- [49] G. Parisi and Y.S. Wu, *Sci. Sinica* **24** (1981) 483.
- [50] P. H. Damgaard and H. Hüffel, *Phys. Rep.* **152** (1987) 227.
- [51] E. Nelson, *Quantum Fluctuations*, Princeton University Press 1985. see Chapt. 4, ‘Physics or formalism?’
- [52] G.F.R. Ellis and J. P. Uzan, *Am. J. Phys.* **73** (2005) 240.
- [53] M. Consoli and L. Pappalardo, *Gen. Rel. and Grav.* **42** (2010) 2585.
- [54] C. Barcelo, S. Liberati and M. Visser, *Class. Quantum Grav.* **18** (2001) 3595.
- [55] M. Visser, C. Barcelo and S. Liberati, *Gen. Rel. Grav.* **34** (2002) 1719.
- [56] M. Consoli, *Class. Quantum Grav.* **26** (2009) 225008.
- [57] J. S. Bell, How to teach special relativity, in *Speakable and unspeakable in quantum mechanics*, Cambridge University Press 1987, pag. 67.
- [58] H. R. Brown and O. Pooley, The origin of the space-time metric: Bell’s Lorentzian pedagogy and its significance in general relativity, in ‘Physics meets Philosophy at the Planck Scale’, C. Callender and N. Hugget Eds., Cambridge University Press 2000 (arXiv:gr-qc/9908048).
- [59] H. R. Brown, *Physical Relativity. Space-time structure from a dynamical perspective*, Clarendon Press, Oxford 2005.

- [60] M. Consoli and E. Costanzo, Phys. Lett. A **333** (2004) 355.
- [61] P. Ehrenfest, On the crisis of the light-ether hypothesis, Collected Scientific Papers, M. J. Klein Editor, North-Holland 1959, pp. 306-327.
- [62] R. P. Feynman, R. B. Leighton and M. Sands, The Feynman Lectures on Physics, Addison Wesley Publ. Co. 1963, Vol.II, Chapt. 42.
- [63] R. H. Dicke, Phys. Rev. **125** (1962) 2163.
- [64] K. Thorne, Black Holes and Time Warps: Einstein's Outrageous Legacy, W. W. Norton and Co. Inc, New York and London, 1994, see Chapt. 11 'What is Reality?'
- [65] A. M. Volkov, A. A. Izmet'sev and G. V. Skrotskij, Sov. Phys. JETP **32** (1971) 686.
- [66] H. P. Robertson, Rev. Mod. Phys. **21** (1949) 378.
- [67] R. M. Mansouri and R. U. Sexl, Gen. Rel. Grav. **8**(1977) 497.
- [68] For a comprehensive review of the present ether-drift experiments, see H. Müller et al., Appl. Phys. B **77** (2003) 719.
- [69] S. Herrmann, A. Senger, E. Kovalchuk, H. Müller and A. Peters, Phys. Rev. Lett. **95** (2005) 150401.
- [70] H. Müller et al., Phys. Rev. Lett. **99**, 050401 (2007).
- [71] S. Herrmann, et al., Phys.Rev. D **80** (2009) 105011.
- [72] Ch. Eisele, A. Newski and S. Schiller, Phys. Rev. Lett. **103** (2009) 090401.
- [73] A. Kostelecky and N. Russell, arXiv:0801.0287[hep-ph].
- [74] L. D. Landau and E. M. Lifshitz, Fluid Mechanics, Pergamon Press 1959, Chapt. III.
- [75] Ch. Eisele et al., Opt. Comm. **281** (2008) 1189.
- [76] K. Numata, A. Kemery and J. Camp, Phys. Rev. Lett. **93** (2004) 250602.
- [77] P. Antonini, M. Okhapkin, E. Göklü and S. Schiller, Phys. Rev. A **71** (2005) 050101(R).
- [78] M. Nagel et al., Testing Lorentz Invariance by Comparing Light Propagation in Vacuum and Matter, Presented at the Fifth Meeting on CPT and Lorentz Symmetry, Bloomington, Indiana, June 28-July 2, 2010, arXiv:1008.1205 [physics.ins-det].
- [79] H. Müller, Phys. Rev. D **71** (2005) 045004.
- [80] M. Consoli and E. Costanzo, Eur. Phys. Journ. C **54** (2008) 285; *ibidem*, **55** (2008) 469.